

GMB HR84

Housing Relay - 8 Opto In, 4 Outputs

CAN GM Zero

grifo® Mini Module AT89c51CC03

TECHNICAL MANUAL



grifo®
ITALIAN TECHNOLOGY

Via dell' Artigiano, 8/6
40016 San Giorgio di Piano
(Bologna) ITALY
E-mail: grifo@grifo.it



<http://www.grifo.it> <http://www.grifo.com>
Tel. +39 051 892.052 (a. r.) FAX: +39 051 893.661

GMB HR84 & CAN GM Zero Rel. 5.00 Edition 28 October 2004

, GPC®, grifo®, are trade marks of grifo®



GMB HR84

Housing Relay - 8 Opto In, 4 Outputs

CAN GM Zero

grifo® Mini Module AT89c51CC03

TECHNICAL MANUAL

Modular plastic Container **DIN 50022 Modulbox**, model **M4 HC53**; size: front **90 x 71 mm**, height **58 mm**; mounting on **Omega** rail DIN 46277-1 and DIN 46277-3; **CAN GM Zero** already installed on the **28 pin** socket; **8** Optocoupled Inputs that can be both **NPN** or **PNP**; status of **8** inputs shown by **8 LEDs**; two inputs can perform **Interrupt** functions; three inputs can perform **Counter** functions; **4 Relay** Outputs **5 A**; status of 4 outputs shown by **4 LEDs**; four outputs can perform automatic timing functions; **1 TTL** output driven by **RTC** and visualized by a specific LED; Serial Line in RS 232, RS 422, RS 485, current loop or TTL; 1 analog signal for **A/D** conversion with selectable full range; all signals can be connected through connectors featuring Normalized pin out; **3 I/O TTL** signals; **I²C BUS** available on connector for external devices; **CAN** serial line; **Switching** power supply on board; protection of on board logic, through **TransZorb**; power supply in **DC** or in **AC**: 10 ÷ 40 Vdc or 8÷24 Vac for logic supply; possibility to manage internal **FLASH** and **EEPROM** in **In System Programming** mode; free software for PC, downloadable from **ATMEL** web site, to support **ISP** programming upload the generated code into on-board **FLASH** memory; wide range of development software available: **C** Compilers (μ C/51); **BASIC** Compilers (**BASCOM 8051**); **LADDER** Compilers (**LadderWORK**); etc.; several demo programs and use examples provided as source code completely commented available for every development structure

grifo®
ITALIAN TECHNOLOGY

Via dell' Artigiano, 8/6
40016 San Giorgio di Piano
(Bologna) ITALY
E-mail: grifo@grifo.it



<http://www.grifo.it> <http://www.grifo.com>
Tel. +39 051 892.052 (a. r.) FAX: +39 051 893.661

GMB HR84 & CAN GM Zero Rel. 5.00 Edition 28 October 2004

, GPC®, grifo®, are trade marks of grifo®

DOCUMENTATION COPYRIGHT BY **grifo®**, ALL RIGHTS RESERVED

No part of this document may be reproduced, transmitted, transcribed, stored in a retrieval system, or translated into any language or computer language, in any form or by any means, either electronic, mechanical, magnetic, optical, chemical, manual, or otherwise, without the prior written consent of **grifo®**.

IMPORTANT

Although all the information contained herein have been carefully verified, **grifo®** assumes no responsibility for errors that might appear in this document, or for damage to things or persons resulting from technical errors, omission and improper use of this manual and of the related software and hardware.

grifo® reserves the right to change the contents and form of this document, as well as the features and specification of its products at any time, without prior notice, to obtain always the best product.

For specific informations on the components mounted on the card, please refer to the Data Book of the builder or second sources.

SYMBOLS DESCRIPTION

In the manual could appear the following symbols:



Attention: Generic danger



Attention: High voltage



Attention: ESD sensitive device

Trade Marks

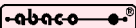
 , GPC® , **grifo®** : are trade marks of **grifo®**.

Other Product and Company names listed, are trade marks of their respective companies.

GENERAL INDEX

INTRODUCTION	1
CARD VERSION	3
NOTE ABOUT MINI MODULE NAME	3
GENERAL INFORMATION	4
ANALOG INPUT	6
OPTOCOUPLED DIGITAL INPUT LINES	6
DIGITAL RELAYS OUTPUTS	6
I/O TTL SIGNALS	6
I²C BUS LINES	8
POWER SUPPLY SECTION	8
CAN INTERFACE	8
SERIAL COMMUNICATION	9
TECHNICAL FEATURES	10
GENERAL FEATURES	10
PHYSICAL FEATURES	10
ELECTRIC FEATURES	11
INSTALLATION	12
CONNECTIONS	12
CN5 - POWER SUPPLY CONNECTOR	12
CN3 - I²C BUS LINE CONNECTOR	13
CN2 - SERIAL LINE CONNECTOR	14
CN6 - OPTOCOUPLED DIGITAL INPUTS CONNECTOR	16
CN1 - RELAYS OUTPUTS CONNECTOR GROUPS A AND B	18
CN4 - TTL I/O, A/D, ETC. CONNECTOR	20
INTERRUPTS	21
I/O CONNECTION	21
POWER SUPPLY	22
BACK UP	24
ANALOG INPUT	24
CORRESPONDANCE OF SIGNALS	24
HOW TO START	26
PERIPHERAL DEVICES SOFTWARE DESCRIPTION	36
RELAYS OUTPUTS	36
SERIAL LINE	36
I²C BUS	36
OPTOCOUPLED INPUTS	37
RTC + SRAM	37
DIGITAL TTL I/O	38
APPENDIX A: ALPHABETICAL INDEX	A-1

FIGURE INDEX

FIGURE 1: POSITION OF CARD RELEASE OF CAN GM ZERO AND GMB HR84	3
FIGURE 2: BLOCKS DIAGRAM	5
FIGURE 3: SNAPSHOT OF GMB HR84 AND MINI MODULE CAN GM ZERO	7
FIGURE 4: CN5 - POWER SUPPLY CONNECTOR	12
FIGURE 5: CN3 - I ² C BUS LINE CONNECTOR	13
FIGURE 6: I ² C BUS CONNECTION DIAGRAM.....	13
FIGURE 7: CN2 - SERIAL LINE CONNECTOR	14
FIGURE 8: SERIAL COMMUNICATION BLOCK DIAGRAM.....	15
FIGURE 9: RS 232 PC POINT TO POINT CONNECTION EXAMPLE	15
FIGURE 10: CN6 - OPTOCOUPLED DIGITAL INPUTS CONNECTOR	16
FIGURE 11: OPTOCOUPLED INPUTS BLOCK DIAGRAM.....	17
FIGURE 12: OPTOCOUPLED INPUTS CONNECTION DIAGRAM	17
FIGURE 13: CN1 - RELAYS OUTPUTS CONNECTOR GROUPS A AND B	18
FIGURE 14: RELAY OUTPUT A AND B BLOCK DIAGRAM	19
FIGURE 15: RELAY OUTPUT A AND B CONNECTION DIAGRAM	19
FIGURE 16: CN4 - TTL I/O, A/D, ETC. CONNECTOR	20
FIGURE 17: LEDs, CONNECTORS, ETC. LOCATION	23
FIGURE 18: JUMPERS CONNECTION	24
FIGURE 19: TABLE OF CORRESPONDANCE BETWEEN SIGNALS AND RESOURCES	25
FIGURE 20: PICTURE OF POWER SUPPLY EXPS-2	26
FIGURE 21: EXAMPLES TABLES	27
FIGURE 22: FLIP SETTINGS WINDOW (1 OF 3)	28
FIGURE 23: FLIP SETTINGS WINDOWS (2 OF 3)	29
FIGURE 24: FLIP SETTINGS WINDOWS (3 OF 3)	29
FIGURE 25: LOADING A SOURCE FILE WITH BASCOM 8051	31
FIGURE 26: CONFIGURATION OF COMPILER BASCOM 8051	31
FIGURE 27: COMPILATION WITH BASCOM 8051	32
FIGURE 28: LOADING SOURCE FILE WITH μ C/51	32
FIGURE 29: LOADING MAKEFILE (COMPILING CONFIGURATION) WITH μ C/51	33
FIGURE 30: COMPILATION USING μ C/51	33
FIGURE 31: LOADING SOURCE SCHEMATIC WITH LADDER WORK	34
FIGURE 32: COMPILER CONFIGURATION FOR LADDER WORK	34
FIGURE 33: COMPILATION WITH LADDER WORK	35
FIGURE 34: CONNECTIONS EXAMPLE	39

INTRODUCTION

The use of these devices has turned - IN EXCLUSIVE WAY - to specialized personnel. This device is not a **safe component** as defined in directive **98-37/CE**.



Pins of Mini Module are not provided with any kind of ESD protection. They are connected directly to their respective pins of microcontroller. Mini Module is affected by electrostatic discharges. Personnel who handles Mini Modules is invited to take all necessary precautions to avoid possible damages caused by electrostatic discharges.

The purpose of this handbook is to give the necessary information to the cognizant and sure use of the products. They are the result of a continual and systematic elaboration of data and technical tests saved and validated from the manufacturer, related to the inside modes of certainty and quality of the information.

The reported data are destined- IN EXCLUSIVE WAY- to specialized users, that can interact with the devices in safety conditions for the persons, for the machine and for the environment, impersonating an elementary diagnostic of breakdowns and of malfunction conditions by performing simple functional verify operations , in the height respect of the actual safety and health norms.

The informations for the installation, the assemblage, the dismantlement, the handling, the adjustment, the reparation and the contingent accessories, devices etc. installation are destined - and then executable - always and in exclusive way from specialized warned and educated personnel, or directly from the TECHNICAL AUTHORIZED ASSISTANCE, in the height respect of the manufacturer recommendations and the actual safety and health norms.

The devices can't be used outside a box. The user must always insert the cards in a container that respect the actual safety normative. The protection of this container is not threshold to the only atmospheric agents, but specially to mechanic, electric, magnetic, etc. ones.

To be on good terms with the products, is necessary guarantee legibility and conservation of the manual, also for future references. In case of deterioration or more easily for technical updates, consult the AUTHORIZED TECHNICAL ASSISTANCE directly.

To prevent problems during card utilization, it is a good practice to read carefully all the informations of this manual. After this reading, the user can use the general index and the alphabetical index, respectly at the begining and at the end of the manual, to find information in a faster and more easy way.



CARD VERSION

The present handbook is reported to the **GMB HR84** card release **220503** and **CAN GM Zero** card release **140202**. The validity of the bring informations is subordinate to the number of the card release.

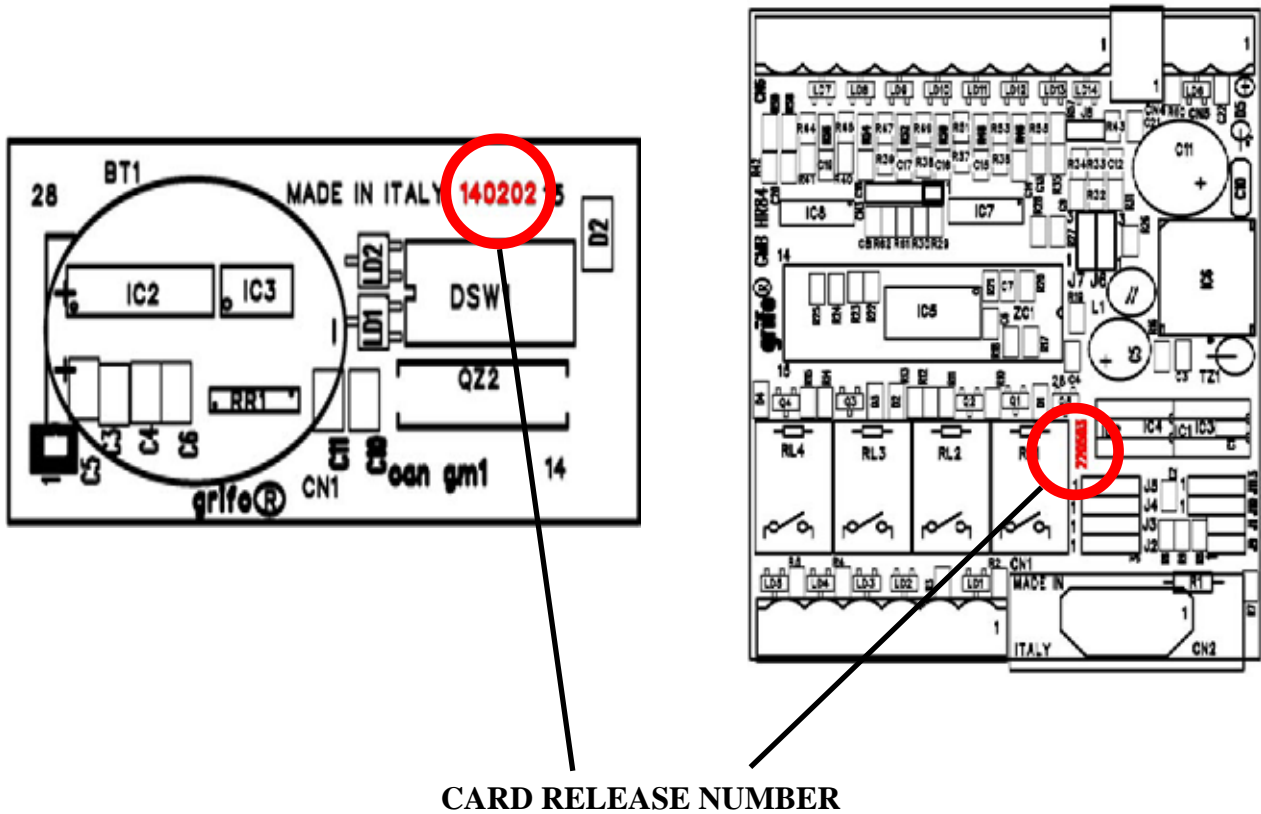

FIGURE 1: POSITION OF CARD RELEASE OF CAN GM ZERO AND GMB HR84

NOTE ABOUT MINI MODULE NAME

Please note the Mini Module name, near the printed circuit revision number.

The name is **CAN GM1**.

CAN GM Zero is made starting from a **CAN GM1** printed circuit where a AT89C51CC03 is installed.

To distinguish **CAN GM1** and **CAN GM Zero** it is compulsive to refer the type of CPU installed, as reported here:

CPU installed:	AT89C51CC03	AT89C51CC01
Mini Module name	CAN GM Zero	CAN GM1

GENERAL INFORMATION

GMB HR84 & CAN GM Zero is a module for DIN rail with a **grifo®** Mini Module CPU type **CAN GM Zero** already installed.

The board features 8 galvanically isolated inputs and 4 relays outputs with LEDs visualizations; an asynchronous serial line; an I²C BUS serial line; an analog input for A/D converter; a PWM output; up to 3 I/O TTL. Its rank is low cost controller, that can work as intelligent peripheral in autonomy and/or remoted inside a wider telecontrol/teleacquisition network.

The union **GMB HR84 & CAN GM Zero** is provided with a standard plastic container with clamps for common Omega rails that can be found in any electric panel.

Low cost of this interface and CPU Mini Modules allow to build with great profit a serie of low budget automation systems.

It is possible to create complete applications in astonishing short times and minimum costs by taking advantage of wide variety of software development tools, like **BASCOM 8051**, unexpensive and portable, C compilers **µC/51** and **HTC 51**, or Ladder WORK, a **LADDER** compiler all available from **grifo®**.

The union is provided with a set of comfortable connectors that can be easily linked to the signals of the field without any additional module, so there is no additional cost.

Such connectors easy also update and assistance phases, that can be needed in time.

Overall features of union **GMB HR84 & CAN GM Zero** are:

- Modular plastic Container **DIN 50022 Modulbox**, model **M4 HC53**
- Size: front **90 x 71 mm**, height **58 mm**
- Mounting on **Omega** rail DIN 46277-1 and DIN 46277-3
- **CAN GM Zero** already installed on the 28 pin socket
- **8 Optocoupled Inputs** that can be both **NPN** or **PNP**
- Status of **8** inputs shown by **8 LEDs**
- Two inputs can perform **Interrupt** functions
- Three inputs can perform **Counter** functions
- **4 Relay Outputs 5 A**
- Status of 4 outputs shown by **4 LEDs**
- Four outputs can perform automatic timing functions
- **1 TTL** output driven by **RTC** and visualized by a specific LED
- **Serial Line** in RS 232, RS 422, RS 485, current loop or TTL
- 1 analog signal for **A/D** conversion with selectable full range
- All signals can be connected through connectors featuring **Normalized** pin out
- **3 I/O TTL** signals
- **I²C BUS** available on connector for external devices
- CAN serial line
- **Switching** power supply on board; protection of on board logic, through **TransZorb**
- Power supply in **DC** or in **AC**: 10 ÷ 40 Vdc or 8÷24 Vac for logic supply
- Possibility to manage internal FLASH and EEPROM in **In System Programming** mode
- Free software for PC, downloadable from ATMEL web site, to support **ISP** programming upload the generated code into on-board FLASH memory
- Wide range of development software available: C compilers (**µC/51**); BASIC compilers (**BASCOM 8051**); LADDER compilers (**LadderWORK**); etc.
- Several demo programs and use examples provided as source code completely commented available for every development structure

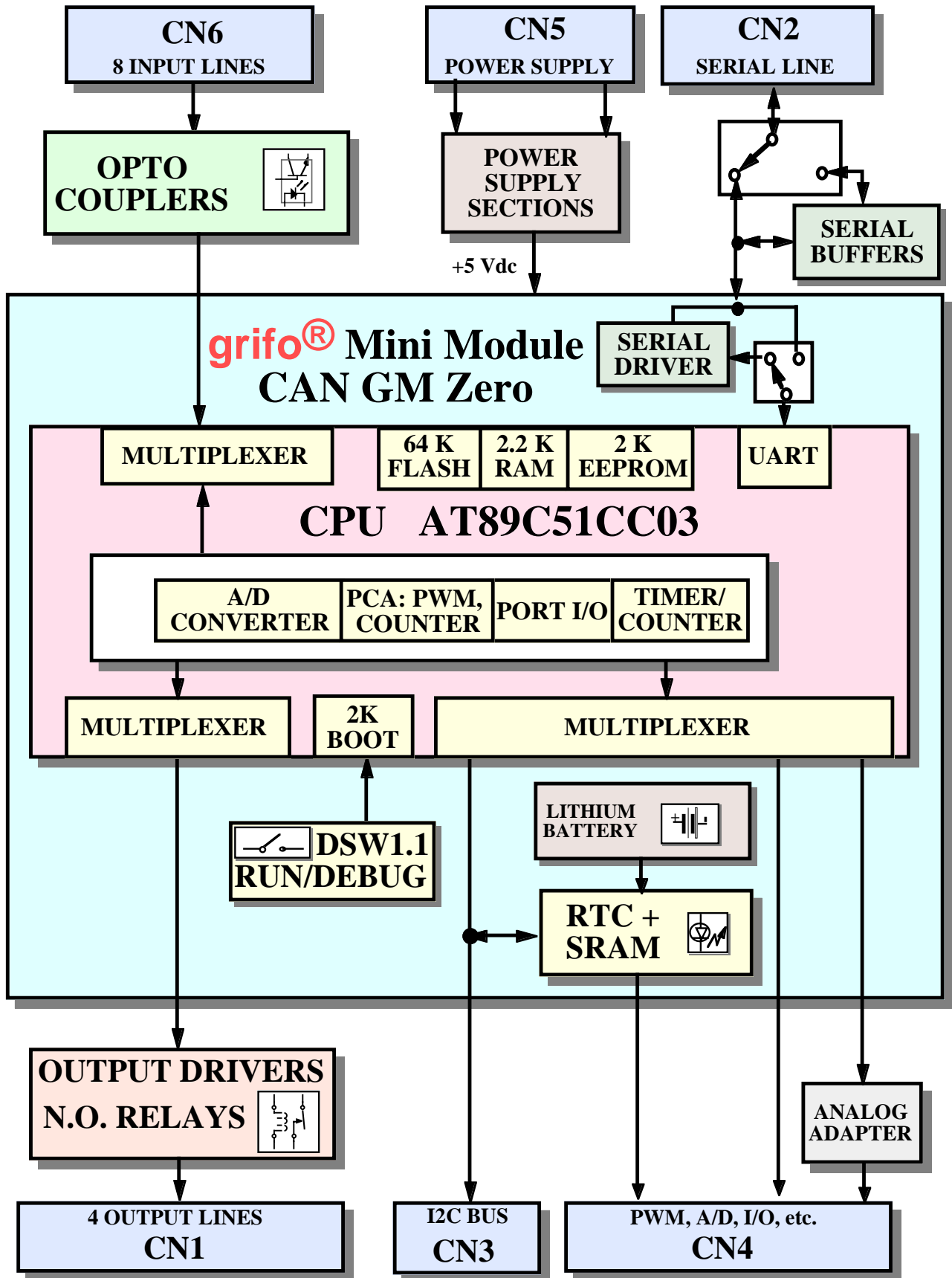

FIGURE 2: BLOCKS DIAGRAM



ANALOG INPUT

One analog input is available on pin 8 of connector CN4 (input signal AN0 corresponding to I/O signals P1.0),

For further information please refer to manual **GMB HR84**.

OPTOCOUPLED DIGITAL INPUT LINES

The card features 8 NPN/PNP inputs connected to two quick release screw terminal connectors and visualized by specific LEDs.

Optocoupled inputs are supplied by a specific external voltage called +Vopto that the user must provide.

For further information please refer to manual **GMB HR84**.

DIGITAL RELAYS OUTPUTS

The board is provided with 4 relays outputs 5 A, normally open, whose status is visualized by 4 LEDs. Each line is driven directly by a signal of **CAN GM Zero**, buffered through a specific driver and connected to a comfortable quick release screw terminal connector to easy interface to the field signals.

For further information please refer to manuals **GMB HR84** and **CAN GM Zero**.

I/O TTL SIGNALS

GMB HR84 features up to 3 digital I/O TTL signals of **CAN GM Zero** connected to a specific connector (CN4).

For further information please refer to manuals **GMB HR84** and **CAN GM Zero**.



FIGURE 3: SNAPSHOT OF GMB HR84 AND MINI MODULE CAN GM ZERO

I²C BUS LINES

GMB HR84 is provided with one connector (CN8) dedicated to I²C BUS, software emulated, connected to two signals of **GMM AC Zero** (P2.0 and P2.1), each provided with a 4.7 kΩ pull-up. This kind of interface allows to connect devices featuring the same communication standard, to easily improve the system performances.

A wide set of software examples explains the management of most common I²C BUS peripherals like A/D and D/A converters, display drivers, memories, temperature sensors, etc.

For this purpose it can be interesting to consider **K51-AVR**, for which both technical manual and electric diagram are available, also a wide set of examples in several languages are available.

GMB HR84 has a Real Time Clock provided with 240 bytes of SRAM already installed and backed by a Lithium battery, so the slave address **A0H** is already taken by this peripheral, eventual third party hardware cannot use it.

For further information please refer to manuals **GMB HR84** and **CAN GM Zero**.

POWER SUPPLY SECTION

GMB HR84 is provided with an efficient switching power supply section, that provides supply +5 Vdc voltage needed by logic and output circuits, in any condition of input load and voltage.

If this section is not present, supply voltages must be provided from an external source.

The board features components and circuits designed to reduce consumptions (including the possibility of power-down and idle working modes of Mini Modules) and to reduce noise sensibility. Remarkable is protection circuit based on TransZorb™ that avoids damages due to incorrect voltages.

To supply optocouplers of galvanically isolated sections a voltage between 12÷24 Vdc is needed. For further information please refer to chapter “ELECTRIC FEATURES” and paragraph “SUPPLY VOLTAGES”.

CAN INTERFACE

GMB HR84 & CAN GM Zero feature an interface for a CAN line.

Such interface is simply a connector for field connection and CAN line termination circuitry, while all other hardware and software characteristics (line driver, bit rate, etc.) are the ones of **CAN GM Zero**, so for further information please refer to manuals of **GMB HR84** and **CAN GM Zero**.

SERIAL COMMUNICATION

GMB HR84 features one AMP MODU II 2x4 P/N 280365 dedicated connector (CN6) for serial communication.

By hardware it is possible to select the electric protocol, through a comfortable set of jumpers and drivers to install.

In detail line can be buffered in **current loop, RS 232, RS 422 or RS 485**; in these last two cases also abilitation and direction of line can be defined using signals P1.3 or P2.3, according to the configuration of jumper J10.

For further information please refer to manuals **GMB HR 168** and **GMM AC Zero**.

TECHNICAL FEATURES

GENERAL FEATURES

On board resources:

- 8 optocoupled digital inputs NPN and PNP
- 2 optocoupled digital inputs NPN and PNP are interrupts
- 2 optocoupled digital inputs NPN and PNP are counters
- 4 relays digital buffered outputs 5 A
- 1 serial line (RS 232, TTL, RS422, RS485, Current Loop, etc.)
- 1 connector for I²C BUS lines
- 1 CAN interface
- 1 RTC with back up Lithium battery and 240 bytes SRAM
- 1 Open Collector RTC interrupt output
- 1 analog input
- 1 eight bit PWM output
- Up to 3 digital I/O TTL
- 1 switching power supply section
- 14 status LEDs + 2 internal LEDs
- 1 internal eight pin Dip Switch

Mini Module: **CAN GM Zero**

Opto input cut-off frequency: 13 KHz

PHYSICAL FEATURES

Size: 90 x 71 x 58 mm (container DIN 50022)
85 x 66 x 32 mm (without container)

Container: DIN 50022 modulbox, model M4 HC53

Montaggio: On Ω rails type DIN 46277-1 and DIN 46277-3

Weight: 172 g

Connectors:

- CN1: 6 pins quick release screw terminal connector
- CN2: 9 pins quick release screw terminal connector
- CN3: 4 pins strip, male, vertical
- CN4: 2x4 vie AMP MODU II, male, vertical
- CN5: 2 pins quick release screw terminal connector
- CN6: 6 pins quick release screw terminal connector

Temperature range: from 0 to 50 centigrad degrees

Relative humidity: 20% up to 90% (without condense)

ELECTRIC FEATURES

Power supply:	10÷40 Vdc or 8÷24 Vac	(control logic)
Power required for logic:	2.3 W	(*)
Output power supply:	+5 Vdc	
Current required by GMB HR84:	310 mA max 16÷75 mA max	(+5 Vdc) (+V opto)
Current on +5 Vdc output:	400 mA - 312 mA - 81 mA = 9 mA	(**)
Relays max voltage:	30 Vdc	
Relays max non inductive current:	5 A	(resistive load)
On board battery:	3.0 Vdc; 180 mAh	
Backup current:	2.3 µA	
Optocouplers input voltage:	+V opto = 8 ÷ 30 Vdc	(*)
Power required for optocouplers:	4.4 W	
Analog input range:	0÷2.5; 0÷10 V	
Analog input impedance:	4.7 kΩ	
Pull-up on I²C BUS dedicated lines:	4.7 kΩ	
Termination network RS 422-485:	Line termination resistor Positive pull up resistor Negative pull down resistor	=120 Ω =3.3 KΩ =3.3 KΩ

(*) The data are referred to 20 C° work temperature (for further information please refer to chapter "POWER SUPPLY VOLTAGE").

(**) In the (worst) case of CAN line always dominating at 5 kbit/sec.

INSTALLATION

In this chapter there are the information for a right installation and correct use of the card. The user can find the location and functions of each connector, LEDs, jumper, etc. and some explanatory diagrams.

CONNECTIONS

Module **GMB HR84 & CAN GM Zero** has 6 connectors that can be linkeded to other devices or directly to the field, according to system requirements. In this paragraph there are connectors pin out, a short signals description (including the signals direction) and connectors location (see figure 23).

CN5 - POWER SUPPLY CONNECTOR

CN5 is a 2 ways, quick release screw terminal connector, vertical, 5.00 mm pitch. CN5 allows to provide power needed by the switching power supply to generate logic control and optocouplers supply voltage.

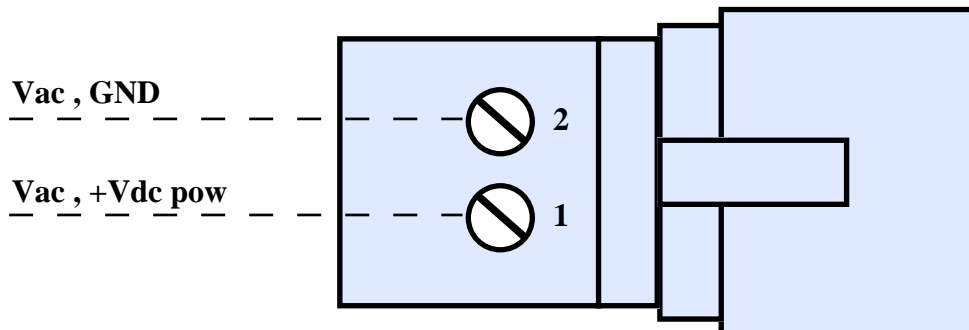

FIGURE 4: CN5 - POWER SUPPLY CONNECTOR

Signals description:

Vac , +Vdc pow = I - Positive terminal of direct supply voltage.
Vac , GND = I - Negative terminal of direct supply voltage.

For further information please refer to paragraphs "POWER SUPPLY" and "ELECTRIC FEATURES".

CN3 - I²C BUS LINE CONNECTOR

CN3 is a 4 ways, male, vertical, strip connector with 2.54mm pitch.

On CN3 is available a standard interface for any I²C BUS peripheral device.

The connector features +5 Vdc supply voltage generated by on board switching power supply that can be connected to external devices or systems.

Signals are TTL compliant, according to I²C BUS standard, their disposition has been designed to reduce interferences and so easy the connection.

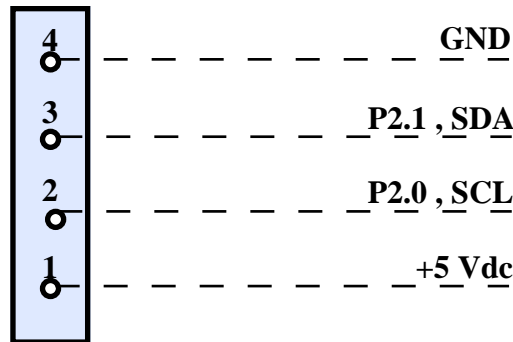

FIGURE 5: CN3 - I²C BUS LINE CONNECTOR

Signals description:

- P2.1, SDA** = I/O - Data signal of I²C BUS software serial line connected to P2.1.
- P2.0, SCL** = O - Clock signal of I²C BUS software serial line connected to P2.0.
- +5 Vdc** = O - Unique +5 Vdc power supply.
- GND** = - Ground.

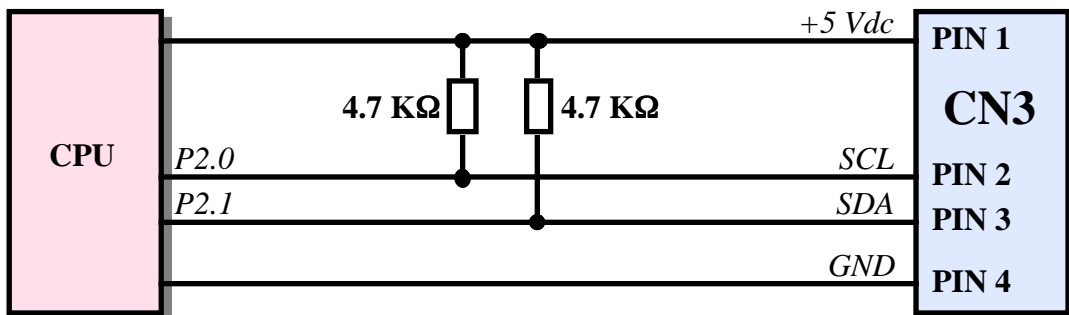

FIGURE 6: I²C BUS CONNECTION DIAGRAM

CN2 - SERIAL LINE CONNECTOR

CN2 is a 9 ways, female, vertical, D-type type connector.

This connector features signals for serial communication in RS 232, RS 422, RS 485, current loop and TTL, performed through hardware module on ZC1 hardware serial port.

Signals position, reported as follows, has been designed to reduce interferences and easy connections to the field, while signals are compliant to CCITT standard of protocol used.

For further information please refer to figure 8 or to the manuals of **GMB HR84** and **CAN GM Zero**.

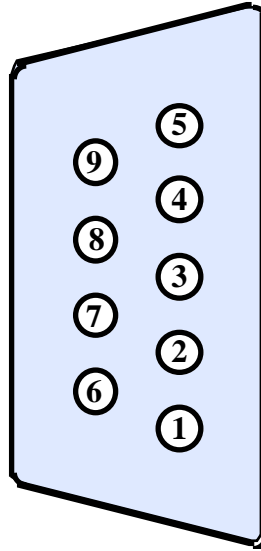

FIGURE 7: CN2 - SERIAL LINE CONNECTOR

<i>Pin</i>	<i>Signal</i>	<i>Direction</i>	<i>Description</i>
<u>RS 232 serial line (please see paragraph "SERIAL COMMUNICATION SELECTION"):</u>			
2	RX RS232	= I -	Receive Data for RS 232.
3	TX RS232	= O -	Transmit Data for RS 232.
5	GND	= -	Ground signal.

<u>RS 422 serial line (please see paragraph "SERIAL COMMUNICATION SELECTION"):</u>			
1	RX- RS422	= I -	Receive Data Negative for RS 422.
2	RX+ RS422	= I -	Receive Data Positive for RS 422.
3	TX- RS422	= O -	Transmit Data Negative for RS 422.
4	TX+ RS422	= O -	Transmit Data Positive for RS 422.
5	GND	= -	Ground signal.

<u>RS 485 serial line (please see paragraph "SERIAL COMMUNICATION SELECTION"):</u>			
1	RXTX+ RS485	= I/O-	Receive/Trasmit Data Positive for RS 485.
2	RXTX- RS485	= I/O-	Receive/Trasmit Data Negative for RS 485.
5	GND	= -	Ground signal.

<u>Current Loop serial line (please see paragraph "SERIAL COMMUNICATION SELECTION"):</u>			
9	RX- C.L.	= I -	Receive Data Negative for Current Loop.
8	RX+ C.L.	= I -	Receive Data Positive for Current Loop.
7	TX- C.L.	= O -	Transmit Data Negative for Current Loop.
6	TX+ C.L.	= O -	Transmit Data Positive for Current Loop.
5	GND	= -	Ground signal.

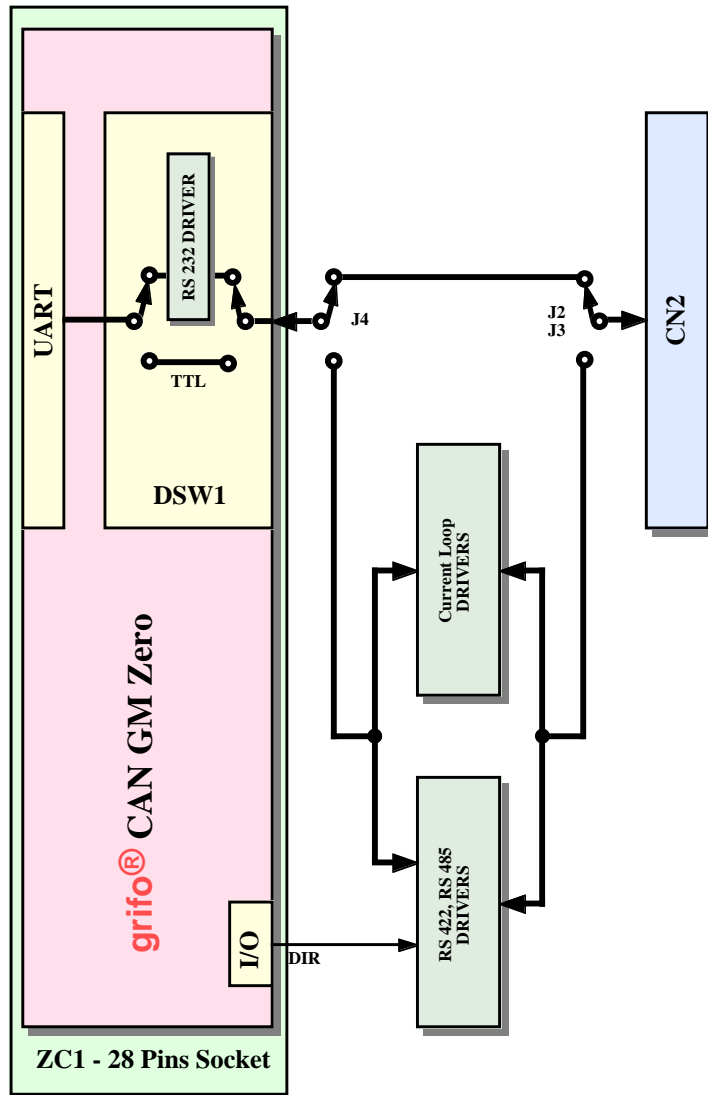

FIGURE 8: SERIAL COMMUNICATION BLOCK DIAGRAM

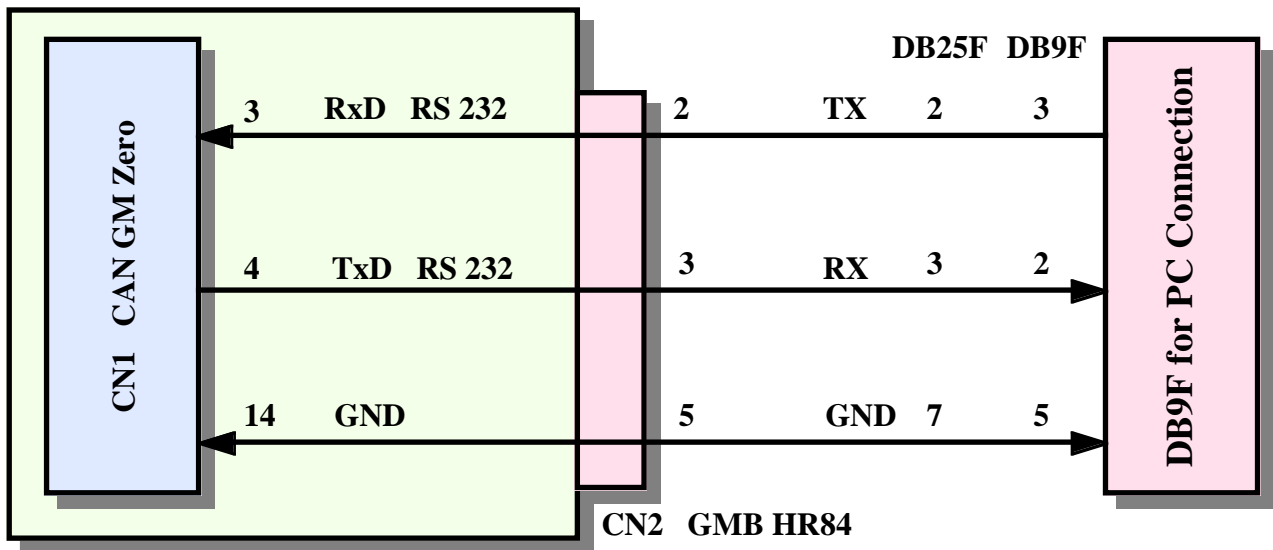

FIGURE 9: RS 232 PC POINT TO POINT CONNECTION EXAMPLE

CN6 - OPTOCOUPLED DIGITAL INPUTS CONNECTOR

CN6 is a 9 ways, quick release, screw terminal connector, pitch 5.0 mm.

CN6 is used to connect the 8 optocoupled NPN or PNP input signals that the card manages and are visualized by green LEDs.

Two of these **inputs** (IN3 and IN4) are connected directly to **interrupt** signals, so they can generate an immediate interrupt request to the CPU.

Two more of these **inputs** (IN5 and IN6) are connected to the external trigger of timer/counters, so transitions on these inputs can be **counted by hardware** by CPU.

Please refer to figure 19 for further information.

Connector also features the common pin where to connect one input to close it.

These signals are software managed through **GMM AC Zero** I/O ports have been carefully selected to take advantage of **grifo®** Mini Modules internal peripherals.

For further information please refer to manual **GMB HR84**.

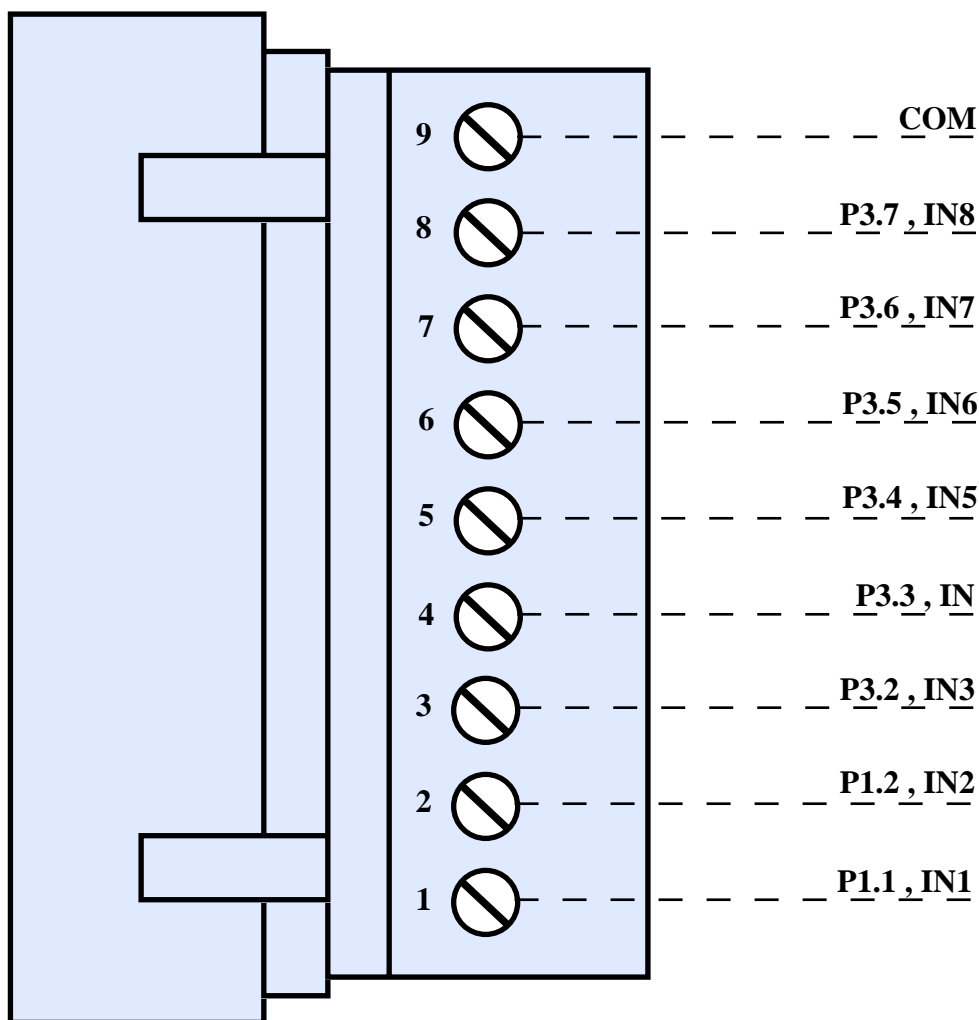

FIGURE 10: CN6 - OPTOCOUPLED DIGITAL INPUTS CONNECTOR

Signals description:

- Px.y, INn** = I - n-th optocoupled input type NPN or PNP, connected to indicated port.
- COM** = - Common pin where an input must be connected to close it.

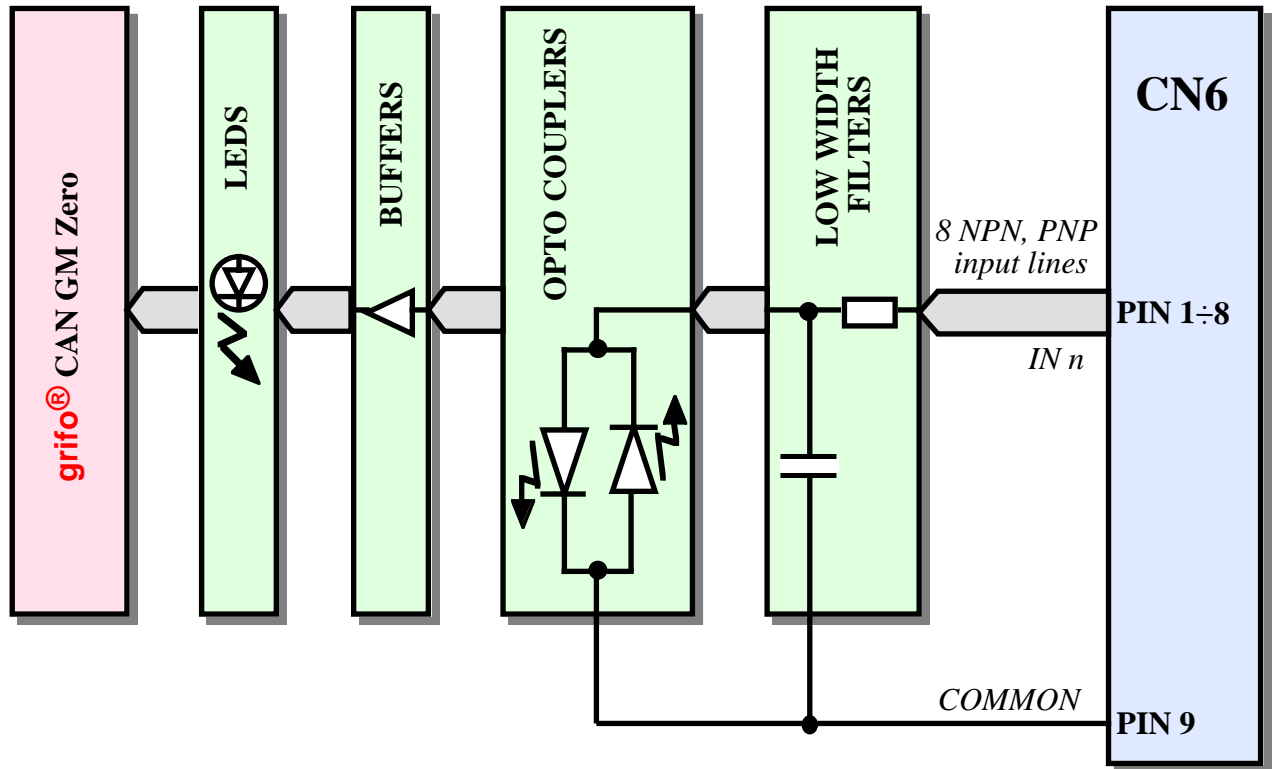

FIGURE 11: OPTOCOUPLED INPUTS BLOCK DIAGRAM

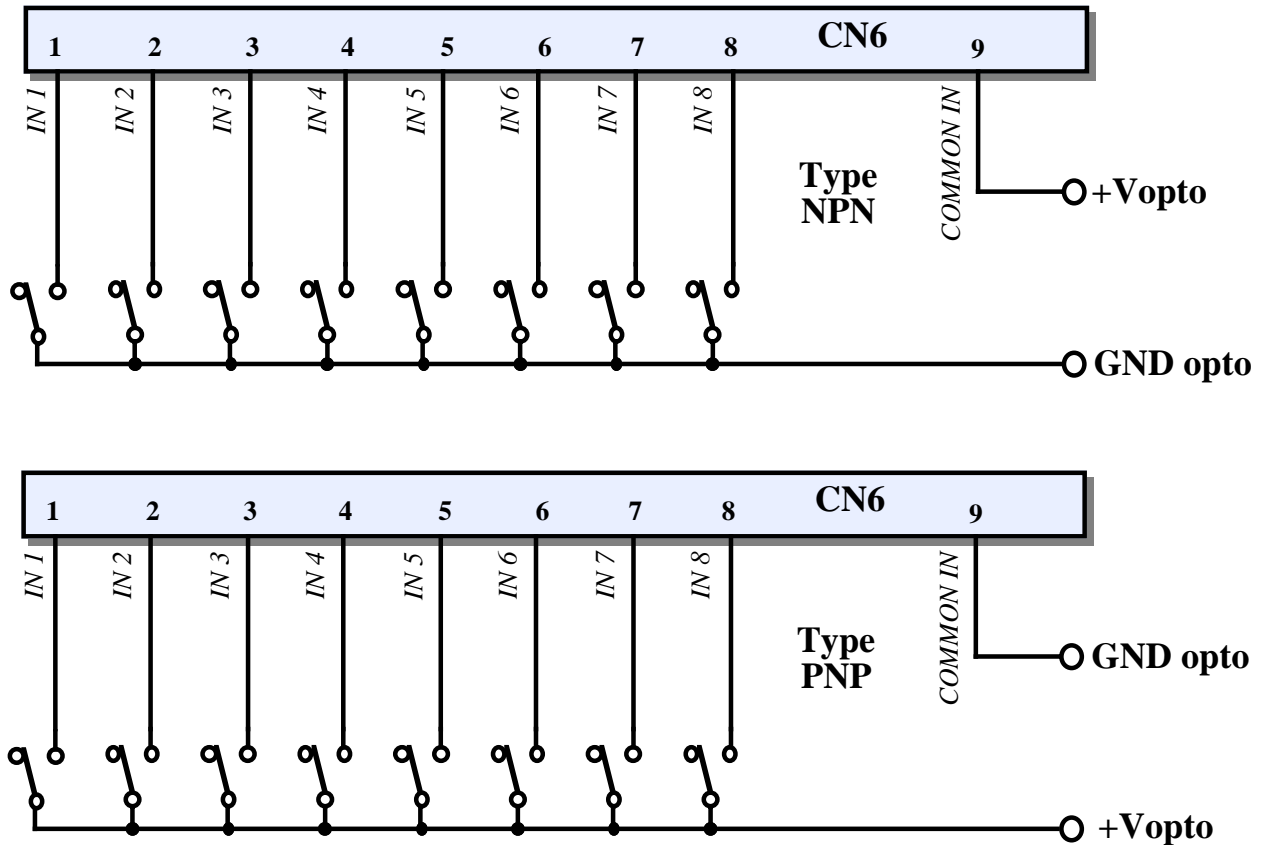

FIGURE 12: OPTOCOUPLED INPUTS CONNECTION DIAGRAM

CN1 - RELAYS OUTPUTS CONNECTOR GROUPS A AND B

CN1 is a 6 ways, quick release screw terminal connector, pitch 5.0 mm.

This connector allows to connect 4 normally open contacts and common pins relays outputs available on **GMB HR84**.

Please remark that maximum (resistive) load for each line is **5 A** and maximum voltage is **30 Vdc**. These signals are software managed through **CAN GM Zero I/O** ports, opportunely buffered, and selected carefully to easy management (please refer to chapter “PERIPHERAL DEVICES SFOTWARE DESCRIPTION”).

For further information please refer to manual **GMB HR84**.

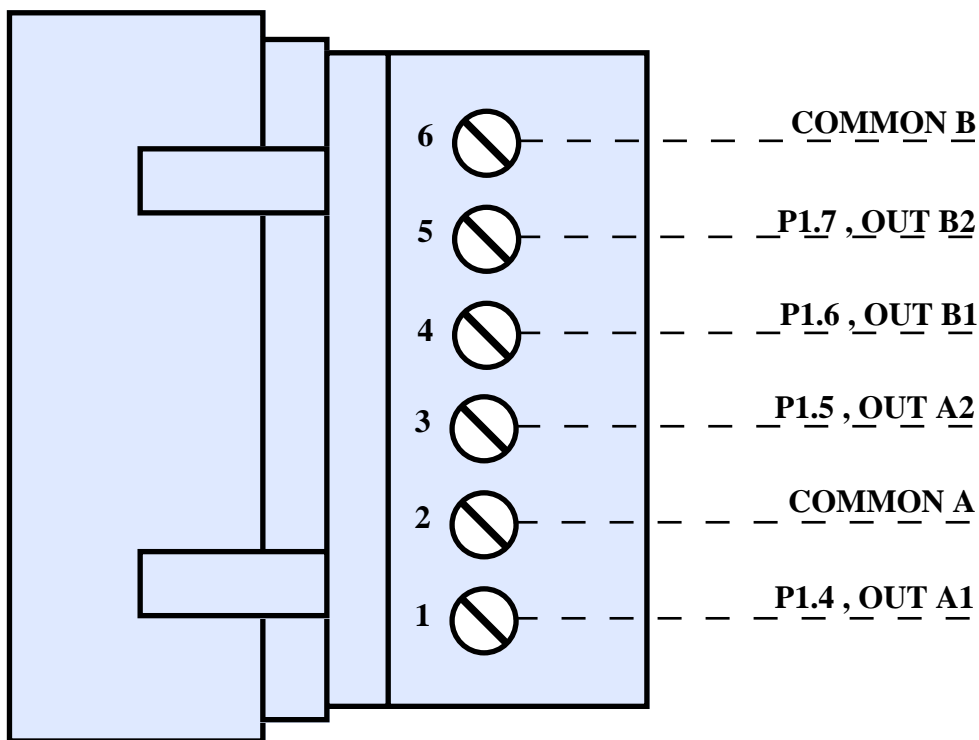

FIGURE 13: CN1 - RELAYS OUTPUTS CONNECTOR GROUPS A AND B

Signals description:

- P1.x, OUT An** = O - Normally open contact for n-th relay of group A, connected to P1.x.
- COMMON A** = - Common contact for relays of group A.
- P1.x, OUT Bn** = O - Normally open contact for n-th relay of group B, connected to P1.x.
- COMMON B** = - Common contact for relays of group B.

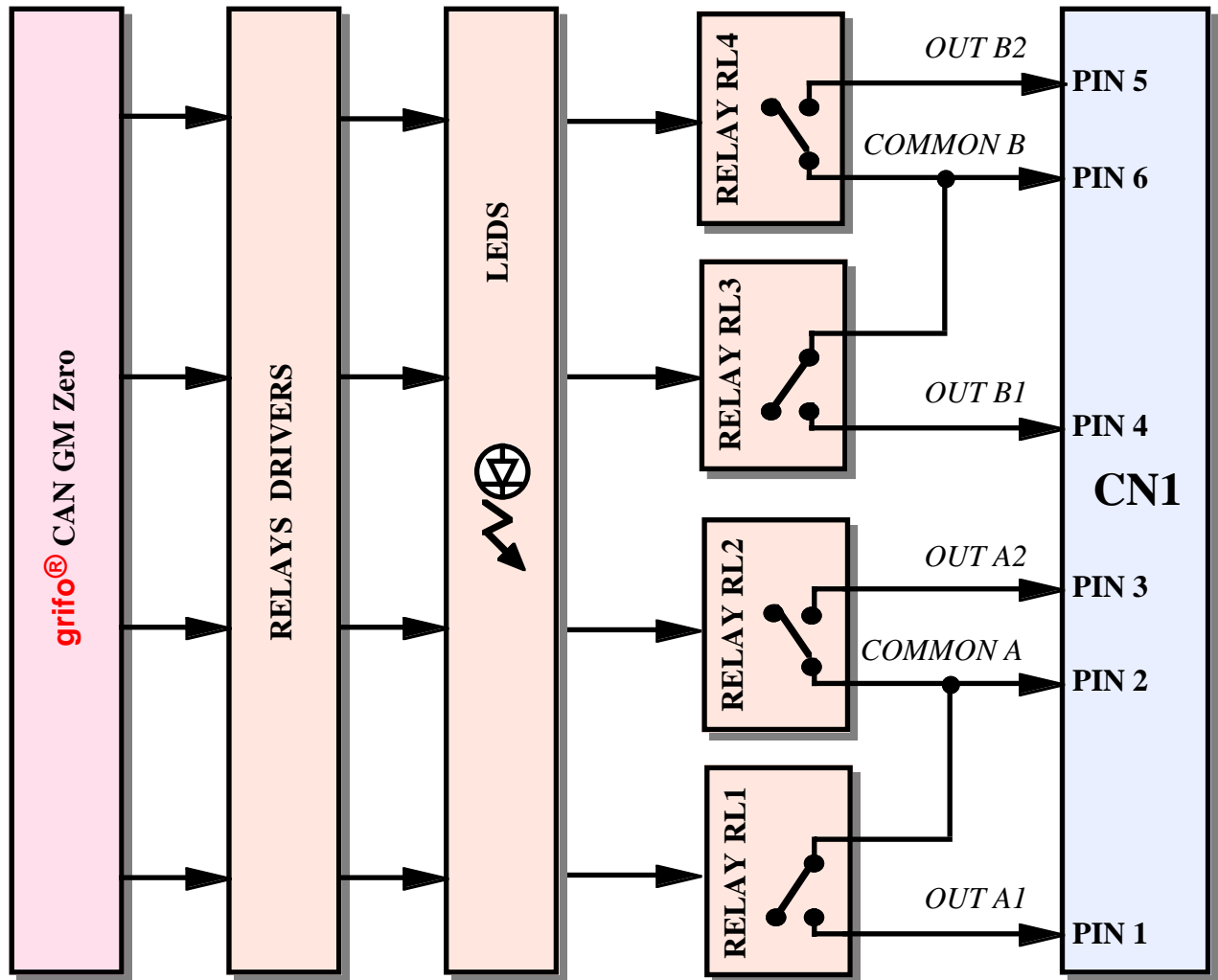

FIGURE 14: RELAY OUTPUT A AND B BLOCK DIAGRAM

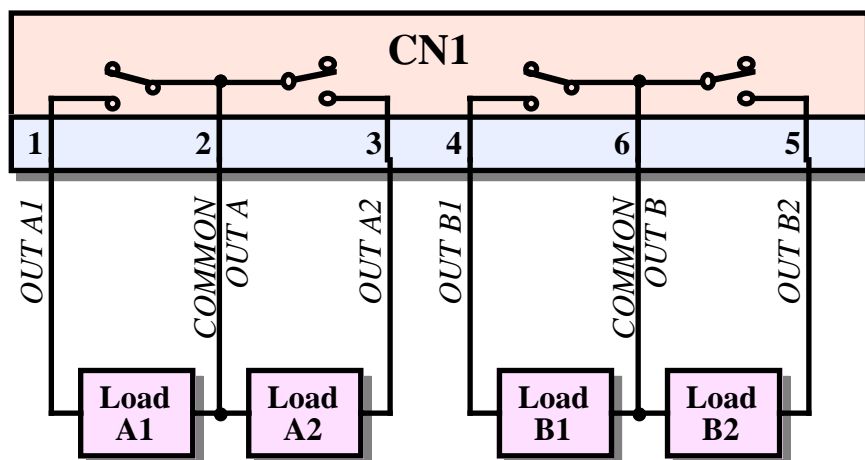

FIGURE 15: RELAY OUTPUT A AND B CONNECTION DIAGRAM

CN4 - TTL I/O, A/D, ETC. CONNECTOR

CN4 is a 8 ways, male, vertical, AMP MODU II 2x4 connector with pitch 2.54 mm.

This connector features +5 Vdc supply voltage (generated by on board switching power supply), up to 5 TTL digital I/O signals and an analog input connected to A/D section.

Pin 4 is connected to Real Time Clock interrupt signal, so it cannot be used as generic I/O signal.

Female connector can be ordered from **grifo**[®] (cod. **CKS.AMP8**) or its parts can be purchased from AMP catalog (P/N 280365: connector and P/N 182206-2: pins to crimp).

It is also possible to order the female connector with pins to crimp already mounted and one meter long cables (**grifo**[®] cod. **AMP8.cable**).

For further information please refer to the manual of **GMB HR84**.

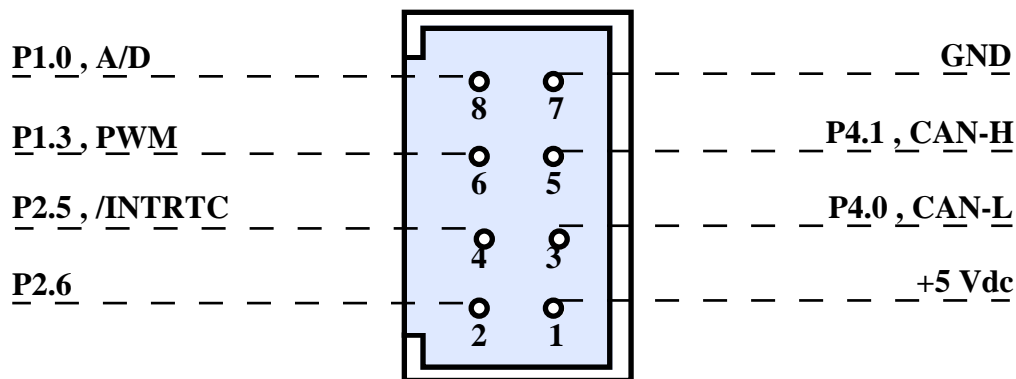

FIGURE 16: CN4 - TTL I/O, A/D, ETC. CONNECTOR

Signals description:

Px.y	= I/O - TTL digital I/O signal, connected to pin x of socket ZC1
A/D	= I - Analog input for A/D converter section (please see manual GMB HR84)
CAN H	= I/O - Differential line high of Mini Module's CAN interface
CAN L	= I/O - Differential line low of Mini Module's CAN interface
PWM	= O - Pulse Width Modulation TTL output of Mini Module
/INTRTC	= I/O - Interrupt signal of Real Time Clock
+5 Vdc	= O - Positive terminal of +5 Vdc power supply.
GND	= - Ground signal.
N. C.	= - No connection.

INTERRUPTS

Possible interrupt sources are:

- Input IN3 of CN1 -> Generates an external interrupt called /INT0.
- Input IN4 of CN1 -> Generates an external interrupt called /INT1.
- Output /INTRTC on CN4 -> Generated by Real Time Clock interrupt of **CAN GM Zero**.
- CPU internal peripherals -> Generate internal interrupts. In detail interrupt sources can be:
Timer 0, Timer 1, Timer 2, PCA, CAN, UART, A/D converter.

Please refer to **GMM AC Zero** manual for further information.

I/O CONNECTION

To prevent possible connecting problems between **GMB HR84 & CAN GM Zero** and the external systems, the user has to read carefully the previous paragraph information and he must follow these instructions:

- For RS 232, RS 422, RS 485, Current Loop, CAN and I²C BUS signals the user must follow the standard rules of each one of these protocols;
- For all TTL signals the user must follow the rules of this electric standard. The connected digital signal must be always referred to card digital ground and if an electric insulation is necessary, then an opto coupled interface must be connected. For TTL signals, the 0V level corresponds to logic state 0, while 5V level corresponds to logic state 1.
- The analog inputs (A/D Converter section) must be connected to signals in the ranges available, at maximum: 0÷10 Vdc according to card configuration. Inputs feature high impedance, anyway an eventual interfacing circuitry should provide low impedance to assure greater stability and precision. Please remark that the analog input on CN4 is provided with filtering capacitors that warrant more stability on the signal to acquire and lower the cut-off frequency.
- For optocoupled input signals, both the contact to acquire and external +Vopto must be connected in serie. In detail, contacts must perform the following connection:

	NPN	PNP
IN x	GND opto	+V opto
COMMON	+Vopto	GND opto

to avoid problems with electric noise, it is suggestable to keep galvanically separated +Vopto and board power supply, this means to keep separate board GND and GND opto.

- Relays outputs must be connected directly to the load to drive (remote control switches, power relays, etc.). Board contact is normally open and can bear **5 A** up to **30 Vdc**. To drive load with different supplies, different COMMONS for two groups of relays are available.

POWER SUPPLY

GMB HR84 & CAN GM Zero is provided with an efficient circuitry that solves in a comfortable and efficient way the problem to supply the card in any condition of use.

Here follow the volages required by the card:

+V opto: Provides power supply to optocouplers of board input section; input voltage must be in the range 8÷30 Vdc and must be provided on connector CN5.

Vac, +Vdc pow, GND: Provide power supply to control logic and to output section of the board through the on board switching power supply; input voltage must be in the range 10 ÷ 40 Vdc or 8 ÷ 24 Vac and must be provided though pins 1 and 2 of CN5 (in case of Vdc, pin 1 must be connected to positive terminal). This allows to supply the cards using standard devices of industrial sector like transformers, batteries, solar cells, etc. Also, if there is the need to supply at +5 Vdc I²C BUS external peripherals from **GMB HR84 & CAN GM Zero**, pins 1 and 4 of CN4 can be used. Please remark that on board switching power supply is provided with single diode rectifier, so in case of Vdc supply, all ground signals (GND) of the card are at the same potential.

To warrant highest immunity against noise and so a correct working of the cards, it is essential that these two volages are galvanically isolated

In order to obtain this power supply **EXPS-2** can be ordered.

This device performs galvanic isolation starting from mains power supply.

GMB HR84 features a **TransZorb™**-based protection circuit to avoid damages from incorrect tensions and break-down of power supply section.

On board power supply is visualized through a LED on the bottom left corner.

Current available to supply external loads using +5 Vdc **must be less than:**

400 mA - current absorbed by **GMB HR84** - current absorbed by Mini Module

in this case:

$$400 \text{ mA} - 310 \text{ mA} - 81 \text{ mA} = 9 \text{ mA}$$

For further information please refer to paragraph "ELECTRIC FEATURES".

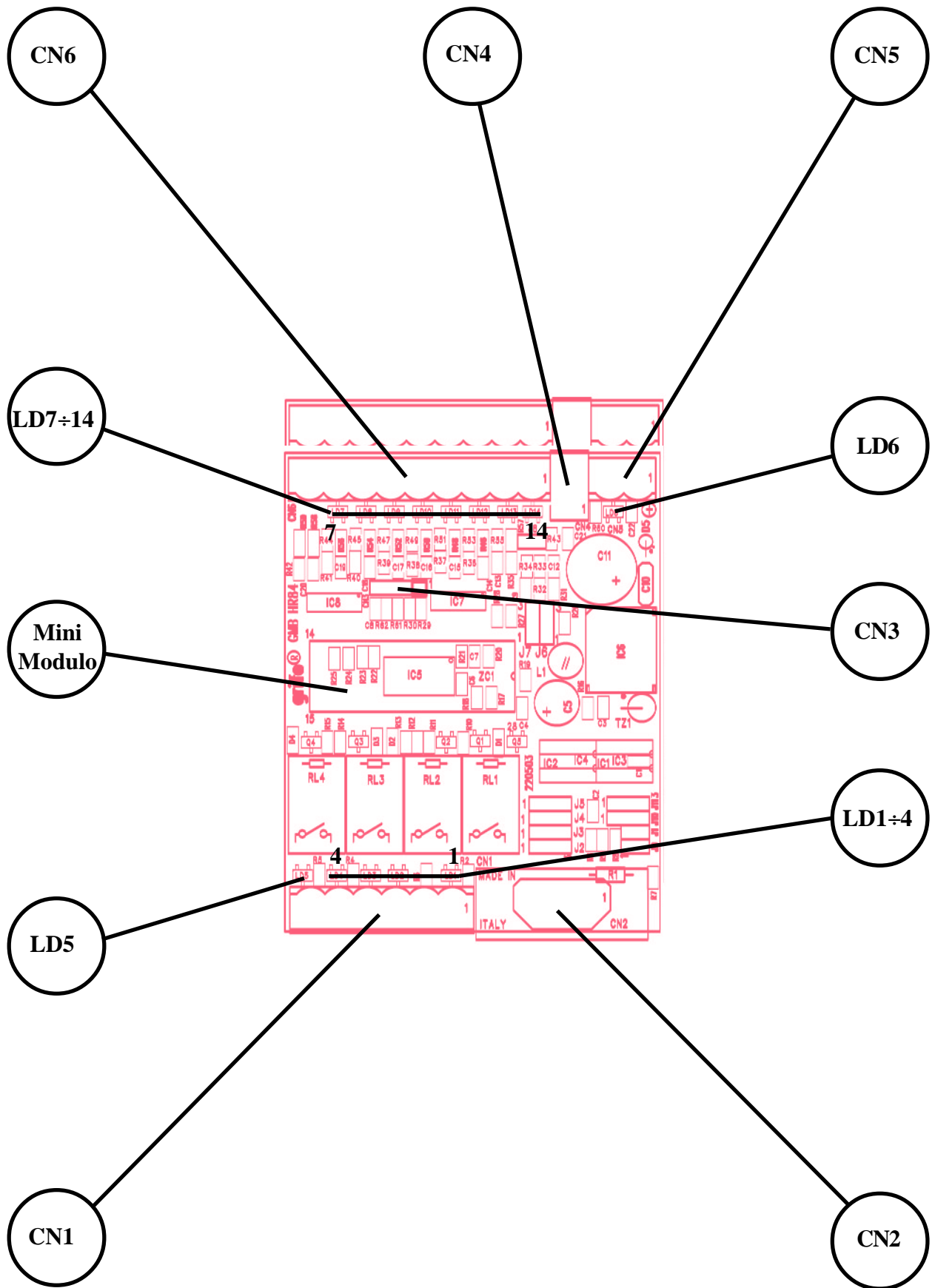

FIGURE 17: LEDs, CONNECTORS, ETC. LOCATION

BACK UP

GMB HR84 & CAN GM Zero features a Real Time Clock and a back up Lithium battery already installed. Lithium battery keeps the time and the content of SRAM even when power supply is off, if dip switch DSW1.6 is ON. By default, DSW1.6 is OFF.

For further information, please refer to manual **GMB HR84**.

ANALOG INPUT

GMB HR84 & CAN GM Zero features an interface for one analog input that can accept an input voltage in a variable range according to connection of jumper J6.

For further information please refer to manual of **GMB HR84**.

CORRESPONDANCE OF SIGNALS

All hardware resources of **GMB HR84 & CAN GM Zero** are managed by **CAN GM Zero** through signals and peripherals of local microcontroller, Atmel AT89C51CC03.

To have the complete control of such resources, it is enough to refer to the table in the near page, which indicates the signal and/or peripheral that drives a specific resource.

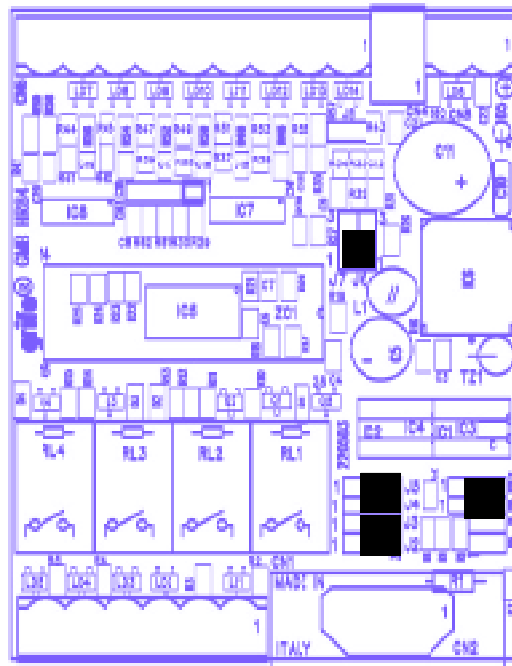

FIGURE 18: JUMPERS CONNECTION

Connector GMB HR84	PIN	Signal GMB HR84	PURPOSE	PIN CN1 CAN GM0	Signal CAN GM0
OPTO INPUTS	1	Input 1	Optocoupled input n° 1.	pin 26	P1.1
	2	Input 2	Optocoupled input n° 2 or counter PCA.	pin 25	P1.2, ECI
	3	Input 3	Optocoupled input n° 3 or Interrupt 0.	pin 19	P3.2, /INT0
	4	Input 4	Optocoupled input n° 4 or Interrupt 1.	pin 18	P3.3, /INT1
	5	Input 5	Optocoupled input n° 5 or counter Timer 0.	pin 17	P3.4, T0
	6	Input 6	Optocoupled input n° 6 or counter Timer 1.	pin 16	P3.5, T1
	7	Input 7	Optocoupled input n° 7.	pin 15	P3.6
	8	Input 8	Optocoupled input n° 8.	pin 13	P3.7
	9	Common pin of optocoupled inputs			
RELAY OUTPUTS	A1	Output 1	Relay output 5 A n° 1.	pin 23	P1.4
	A	Common pin of buffered relay outputs of group A on connector CN3			
	A2	Output 2	Relay output 5 A n° 2.	pin 22	P1.5
	B1	Output 3	Relay output 5 A n° 3.	pin 21	P1.6
	B	Common pin of buffered relay outputs of group B			
	B2	Output 4	Relay output 5 A n° 4.	pin 20	P1.7
AMP 8 I/O	pin 1	+5 Vdc	Power supply +5 Vdc.	pin 28	+5 Vdc
	pin 2	I/O TTL	I/O TTL.	pin 12	P2.2
	pin 3	CAN L	CAN L.	pin 8	P4.0
	pin 4	/INTRTC	Interrupt of optional RTC or I/O TTL.	pin 5	P2.5
	pin 5	CAN H	CAN H.	pin 9	P4.1
	pin 6	D/A	PWM of CEX0 or I/O TTL.	pin 24	P1.3
	pin 7	GND	Ground of Mini Block.	pin 14	GND
	pin 8	A/D	Input AN0 or I/O TTL.	pin 27	AN0

FIGURE 19: TABLE OF CORRESPONDANCE BETWEEN SIGNALS AND RESOURCES

HOW TO START

One of the most important features is the possibility to program the microprocessor Atmel AT89C51CC03 internal FLASH through RS232 serial connecton without removing Mini Module from socket ZC1.

A) MAKE SERIAL CONNECTION BETWEEN HARDWARE AND PC:

A1) First of all, open the container of **GMB HR84** to install Mini Module **CAN GM Zero** on socket ZC1.

A2) To supply **GMB HR84**, power supply **EXPS-2** can be used. It can provide two galvanicallt isolated tensions, required for the correct working of **GMB HR84 & CAN GM Zero**. Also any other power supply capable to generated the two required voltages can be used.

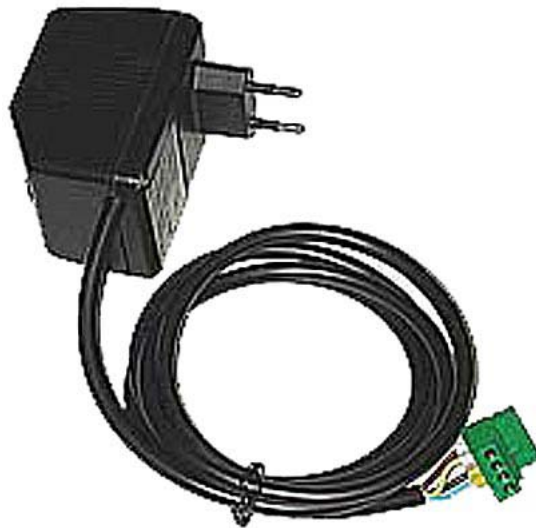

FIGURE 20: PICTURE OF POWER SUPPLY EXPS-2

A3) Make the connection described in figure 9.

A4) Keep ready a terminal emulatore on the PC, configure it to use the serial port conneted to the Mini Module with 19200 baud, 8 data bit, 1 stop bit, no parity.

A5) Set DEBUG mode, that is move dip switch DSW1.1 of **GMM AC Zero** to position ON.

A6) Supply **GMB HR84 & CAN GM Zero**. Please, find the demo program of **GMB HR84 & CAN GM Zero** on **grifo®** CD, the file is called "prgmb84.hex" and can be found from the starting following the path: English | Examples Tables | Mini Block and Mini Modules programs | GMB HR 84.



PROGRAMS FOR MINI MODULES AND MINI BLOCKS													
BOARD TYPE	GET	ASM	Ladder	Abaco® Link BUS	BASIC CBZ80	BASIC BASCOM 8051	BASIC BASCOM AVR	PIC BASIC	BASIC VARI	MCS® Basic 52	C	PASCAL	CPU / BLOCK TYPE
MISCELL.	-	-	-	-	-	●	-	-	-	-	-	-	-
CAN GM0	●	-	-	-	-	●	-	-	-	-	●	-	Atmel T89C51cc03 - 8051 Code
CAN GM1	●	-	-	-	-	●	-	-	-	-	●	-	Atmel T89C51cc01 - 8051 Code
CAN GM2	●	-	-	-	-	●	-	-	-	-	●	-	Atmel T89C51cc02 - 8051 Code
GMM 5115	●	-	-	-	-	●	-	-	-	-	●	-	Atmel T89C5115 - 8051 Code
GMM 876	●	-	-	-	-	-	-	●	-	-	-	-	Microchap PIC16F876A - PIC 14 Code
GMM 932	●	-	-	-	-	●	-	-	-	-	-	-	PHILIPS P89LPC932 - 8051 Code
GMM AC2	●	-	-	-	-	●	-	-	-	-	●	-	Atmel T89C51AC2 - 8051 Code
GMM AM08	●	-	-	-	-	-	●	-	-	-	-	-	Atmel ATMega08 - AVR Code
GMM AM32	●	-	-	-	-	-	●	-	-	-	-	-	Atmel ATMega32 - AVR Code
GMB HR84	●	-	-	-	-	●	●	●	-	-	●	-	Mini Block 8 input opto 4 output relè
GMB HR168	●	-	-	-	-	●	-	-	-	-	●	-	Mini Block 16 input opto 8 output relè



FIGURE 21: EXAMPLES TABLES

B) FLASH REPROGRAMMING:

- B1) Find and save to a comfortable position on your hard drive the file "prgmb84.hex".
- B2) On **grifo**® CD it is also available the utility program FLIP. that manages the ISP programming of microcontroller memories on board of **CAN GM Zero** through the simple serial connection seen at point A; find it and install it on a comfortable position on your hard drive. It is suggested to use version 2.2.0 or greater, the latest version is available on Atmel website: www.atmel.com.
- B3) Put switch 1 of DSW1.1 of **CAN GM Zero** in position ON, to set DEBUG mode.
- B4) Close the terminal emulator.
- B5) Turn off and then turn on again **GMB HR84 & CAN GM Zero**.
- B6) Run ISP programming software installed at step B2.
- B7) Select the CPU to program, that is AT89c51CC03, by pressing the first button on top left, picking the name in the window that appears and pressing OK.

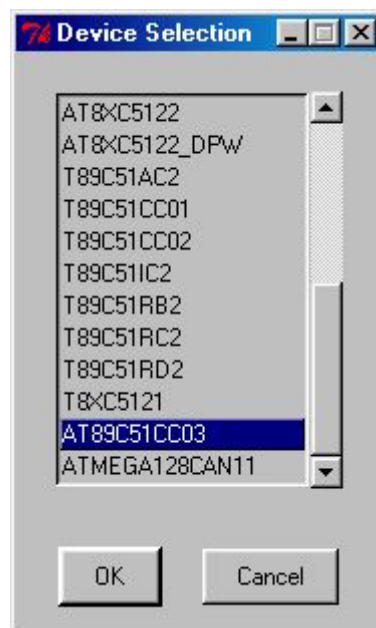

FIGURE 22: FLIP SETTINGS WINDOW (1 OF 3)

B8) Select communication speed with Mini Module by pressing the second button on the top left, picking RS 232 the 115200 and the serial port used to connect the PC to Mini Module then press OK:

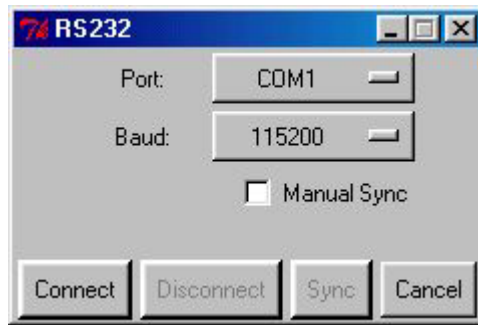

FIGURE 23: FLIP SETTINGS WINDOWS (2 OF 3)

If a window with the message "Timeout Error" should appear after 20 seconds, try to decrease the baud rate; or to repeat point from B1 to here; or verify the correct connection between PC and Mini Module repeating the points from A1 to A4.

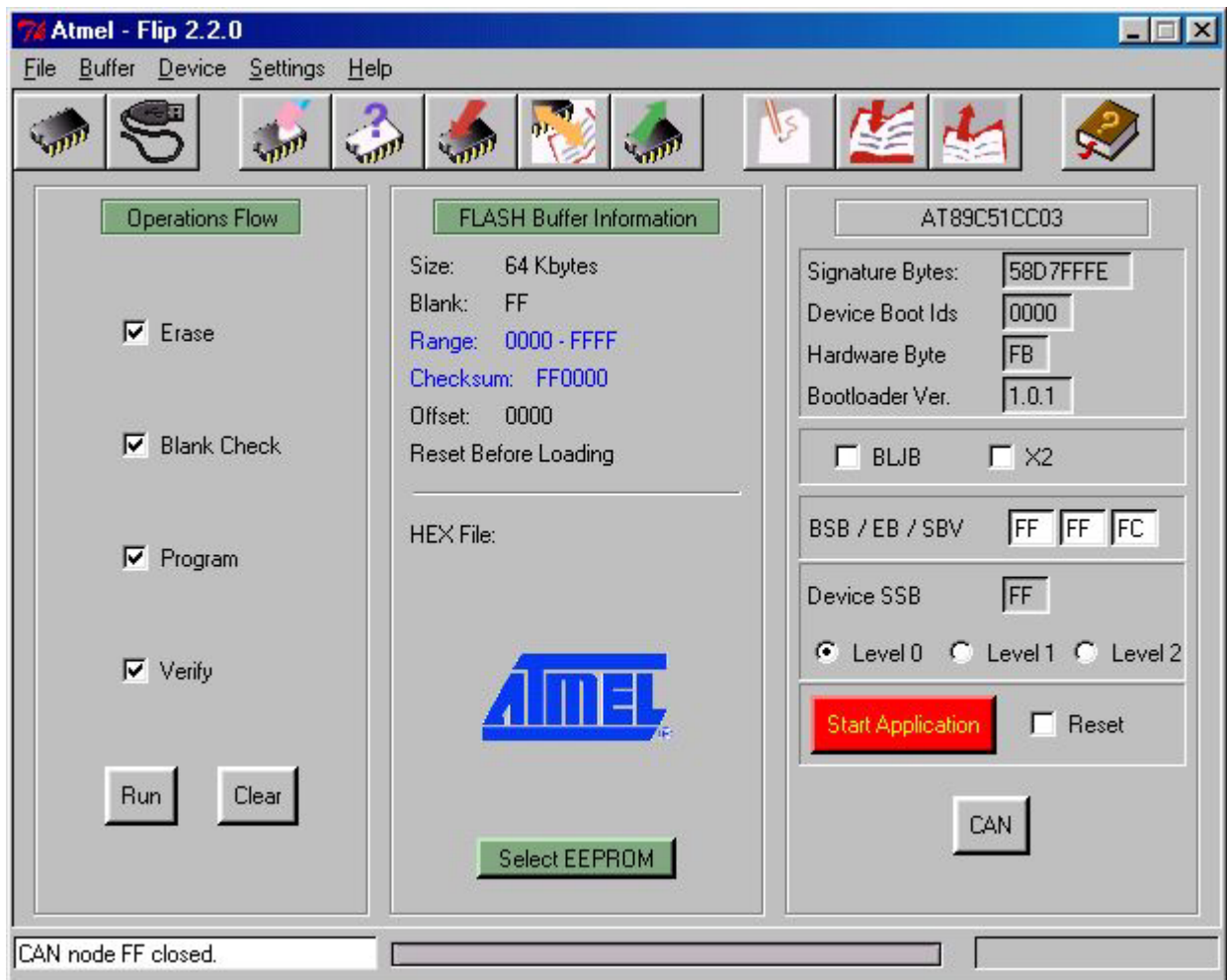

FIGURE 24: FLIP SETTINGS WINDOWS (3 OF 3)

- B9) Make sure that text boxes in the frame "AT89C51CC03" fill with text, like in figure 24.
- B10) Load the file to write in FLASH (that is prgmb84.hex) pressing the third button on top right and selecting the file using the dialog box. In the frame "FLASH Buffer Information" several information about the file just loaded appear; in detail the box "HEX File:" must report the file name.
- B11) Check all the check boxes in the frame "Operations Flow".
- B12) Press button "Run" in the same frame.
- B13) The status bar on the bottom reports operation progress, text box in the bottom left reports operation status, check boxes become red and then green when the respective operation is successfully completed. Wait for "Verify" check box to become red.
- B14) Close **FLIP**.
- B15) Start the terminal emulator configured like in point A4.
- B16) Set RUN mode, that is DSW1.1 OFF.
- B17) Reset or Power off and then on the card; the terminal emulation window now must show the demo program start screen, like in point A4.

C) GENERATING DEMO EXECUTABLE CODE:

- C1) Install on the hard disk of the development P.C. the software environment selected to develop the application program. There are many different software tools that satisfy any customers requirements but here we remind only the most diffused as the BASCOM 8051, μ C/51, LADDER WORK, etc.
- C2) On **grifo**[®] CD in addition to file with the executable code of the demo program, described at point A6, there are also the source file of the same. These have an extension that identifies the used software development tools (for example prgmb84.bas for BASCOM 8051, prgmb84.c for μ C/51 or prgmb84.pjn for LADDER WORK) and they are properly organized inside demo programs tables available on CD, together with possible definition file (prgmb84.mak and canary.h for μ C/51, grifo_mm.dat for BASCOM 8051, etc.). Once these files have been located they must be copied in a comfortable folder on the hard disk of development P.C.
- C3) Compile the source file by using the selected software tools: the file prgmb84.hex must be obtained equal to those available on **grifo**[®] CD and already used at steps B. This operation is very different according to the programming environment selected, so here follows the details:

I) Ricompilation using BASCOM 8051

Ia) When in BASCOM IDE, load the program source with menu File | Open:

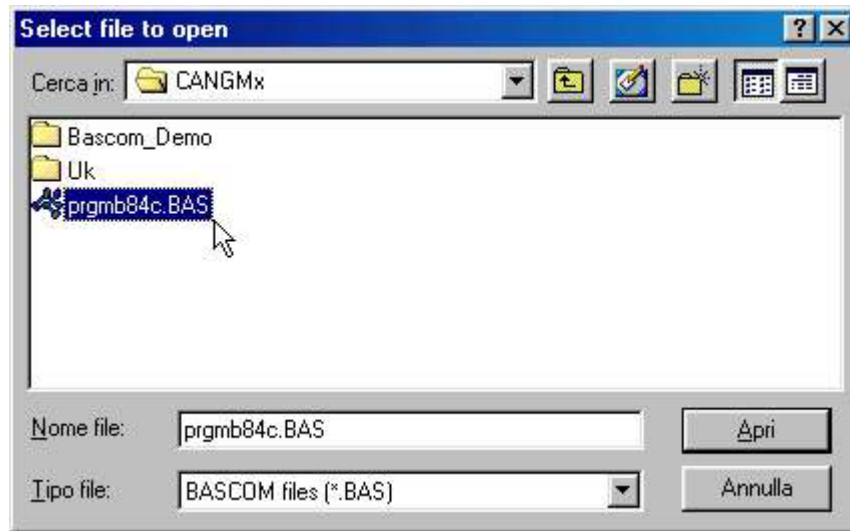

FIGURE 25: LOADING A SOURCE FILE WITH BASCOM 8051

Ib) From menu Options | Compiler | Misc set the value of Byte End to A0, as suggested also in the source code, and press OK:

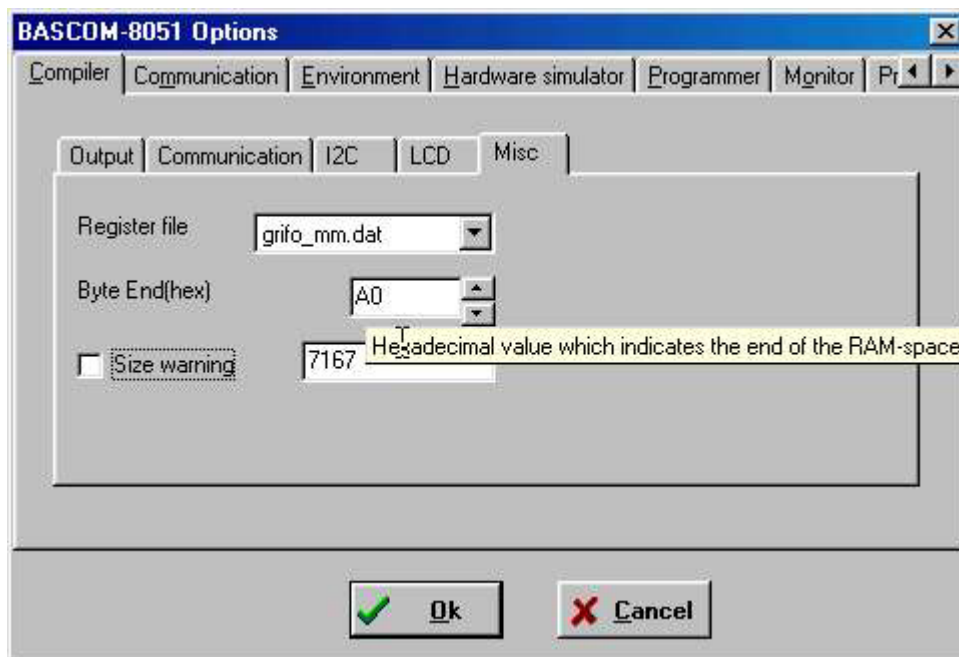

FIGURE 26: CONFIGURATION OF COMPILER BASCOM 8051

Ic) Compile the source file by pressing the button with the icon of an integrated circuit. Presence of file grifo_mm.DAT in BASCOM installation folder is required in order to compile correctly:

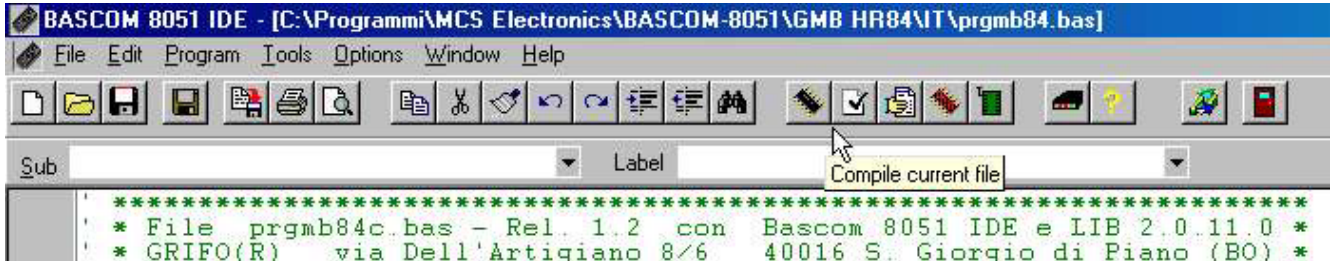

FIGURE 27: COMPILATION WITH BASCOM 8051

II) *Ricompilation with $\mu C/51$*

Iia) After opening standard editor uedit.exe, load the source file pressing the fifth button from the left, the presence of file canary.h in the same folder of file prgmb84.c is required for a correct compilation:

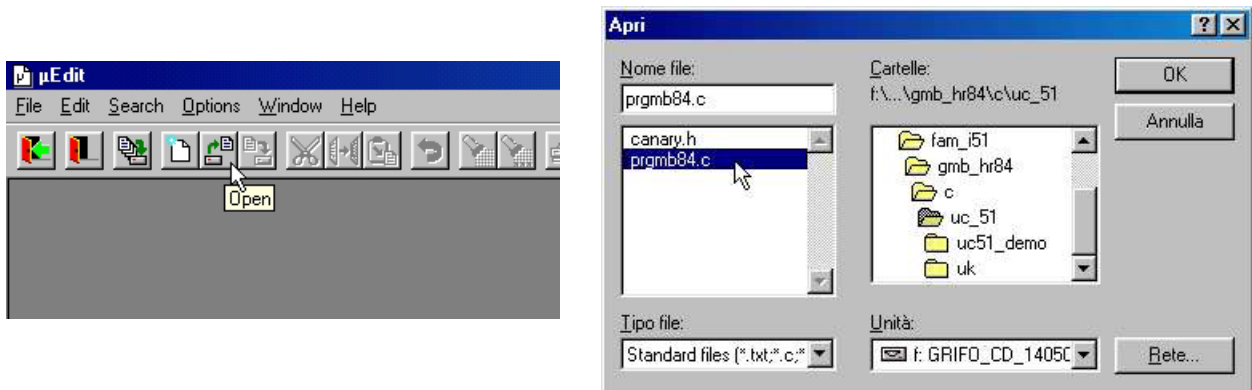

FIGURE 28: LOADING SOURCE FILE WITH $\mu C/51$

Iib) Open also MakeFile editor, that is program umshell.exe, and load file prgmb84.mak with the menu File | Load:

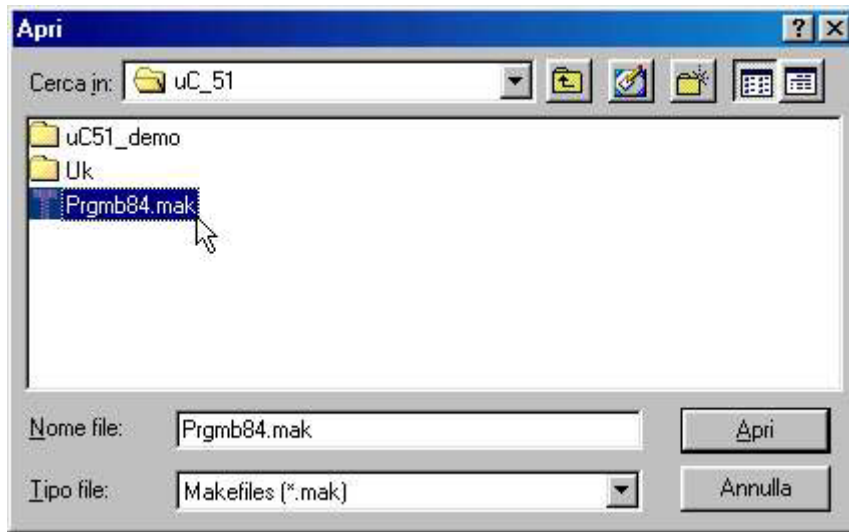

FIGURE 29: LOADING MAKEFILE (COMPILING CONFIGURATION) WITH μ C/51

IIc) Compile the source file pressing the first button from the right:

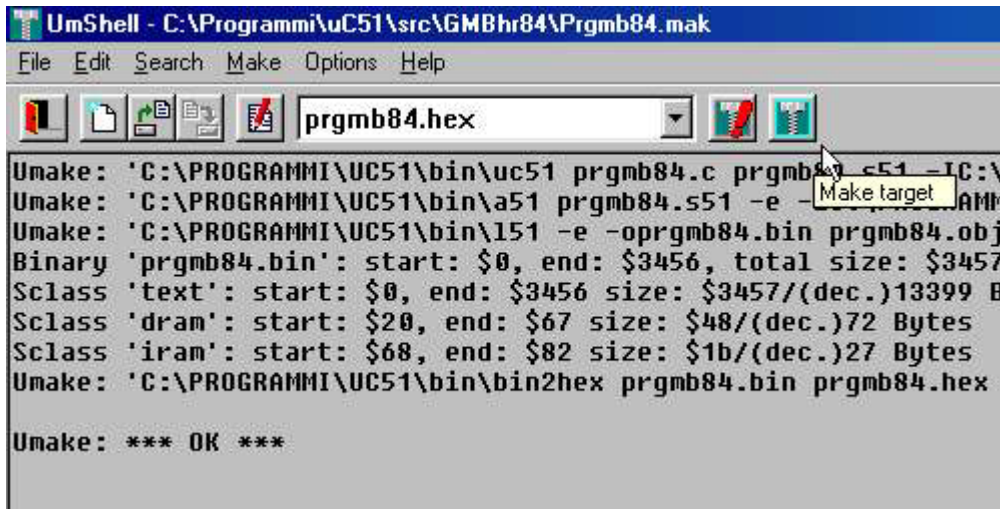

FIGURE 30: COMPILATION USING μ C/51

III) Ricompilation using LADDER WORK.

IIIa) After opening IDE of LADDER WORK, open the schematic file called prgmb84.pjn with menu File | Open:

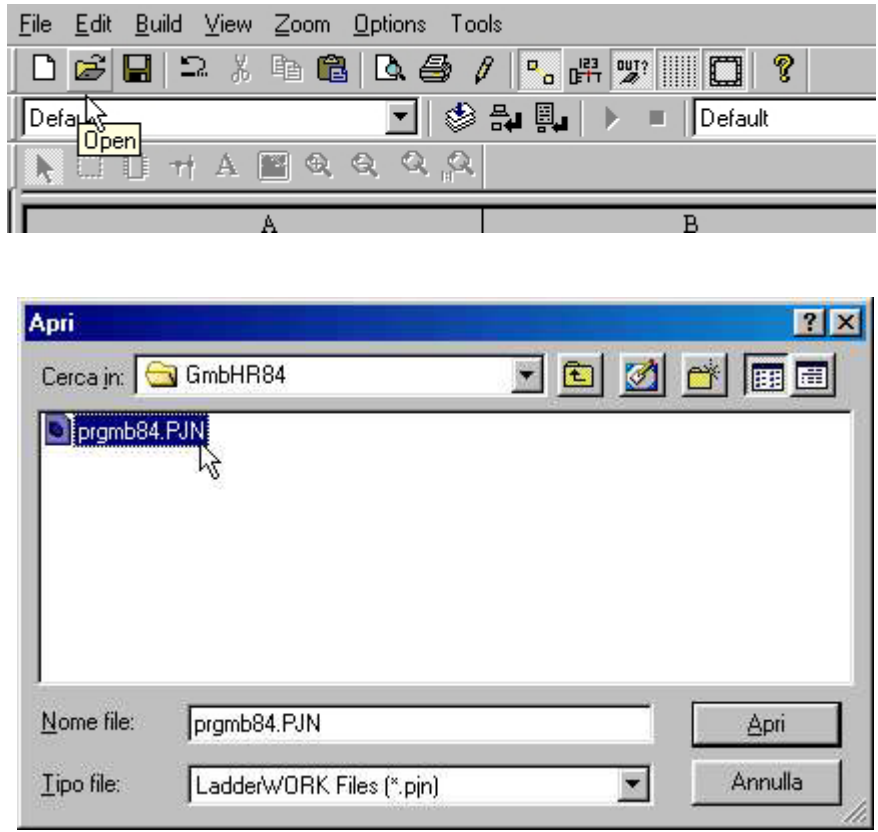

FIGURE 31: LOADING SOURCE SCHEMATIC WITH LADDER WORK

IIIb) Assure that the selected profile is the one specific for CAN GM Zero & GMB HR84:



FIGURE 32: COMPILER CONFIGURATION FOR LADDER WORK

IIIc) Compile the source schematic pressing the first button from the right:

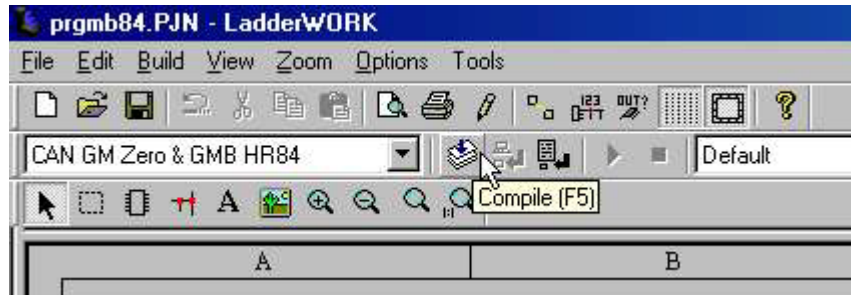

FIGURE 33: COMPILATION WITH LADDER WORK

- C4) Reperform the programming of the obtained HEX file in the Mini Module FLASH, by executing again the points B3÷B17.
About the FLASH MAGIC settings, please remind that they could be inserted only the first time in fact the same program maintains the last setting sucesfully used.

When during execution of the steps above described a problem or a malfunction is found, we suggest to read and repeat again all the steps carefully and if malfunction persists please contact directly **grifo®** technician.

Instead when execution of all the steps above described is right, the user has realized his first application program that coincides with demo of **CAN GM Zero & GMB HR84**.

At this point it is possible to modify the source of the demo/s program according to application requirements and test the obtained program with the steps above listed (from B3 to C4) in cyclic mode, until the developed application program is completely well running.

When this focus is reached the developmnet P.C. can be eliminated, by obtaining a self running card, as below described:

D) PREPARAZIONE DEFINITIVA DELL'APPLICAZIONE

- D1) Impostare modalità RUN (DSW1.1=OFF) e scollegare P.C. di sviluppo.

PERIPHERAL DEVICES SOFTWARE DESCRIPTION

In the previous paragraphs are described the peripheral connections to the field, while in this one there is a specific description of registers meaning and function (please refer to I/O addresses table, for the registers names and addresses values).

For a more detailed description of the devices, please refer to documentation of **GMB HR84** and **CAN GM Zero**.

In the following paragraphs the **D7÷D0** and **.0÷7** indications denote the eight bits of the combination used in I/O operations.

RELAYS OUTPUTS

Status of 4 digital relays outputs is set through 4 signals of 28 pin socket ZC1, which means I/O TTL signals of **CAN GM Zero**.

When the signal of socket ZC1 is set to logic state low (logic 0), the corresponding output is activated (relay contact is connected to its common pin).

Viceversa when the signal is set to logic state high (logic 1) the corresponding output is deactivated (relay open).

As previously said, LEDs LD1÷4 provide a visual indication of digital outputs status (LED ON = output activated).

Summarizing, the correspondance is:

P1.4 , OUT A1	->	LED LD1
P1.5 , OUT A2	->	LED LD2
P1.6 , OUT B1	->	LED LD3
P1.7 , OUT B2	->	LED LD4

SERIAL LINE

The **CAN GM Zero** signals used are the ones called TxD and RxD.

I²C BUS

Signals used are pin 3 of CN3 (SDA) and pin 2 of CN3 (SCL).

Please remark that **CAN GM Zero** is not provided with an hardware I²C BUS interface, so this must be emulated by software using the high level instructions of the development language or the functions that can be found in the demo programs.

Signals SDA and SCL are also provided with 4.7 kΩ pull up resistors.

Only slave addresses from **00H** to **9FH** and from **A1H** to **FFH** can be used by user because Real Time Clock of **CAN GM Zero** is present.

OPTOCOUPLED INPUTS

Status of 8 digital optocoupled inputs can be acquired by software reading the status of corresponding **CAN GM Zero**.

When NPN or PNP inputs are enabled, corresponding signals are at logic state low (logic 0), viceversa when inputs are disabled a logic level high is acquired (logic 1).

As previously said, LEDs LD7÷14 give a visual indication of digital inputs status (LED ON means input actived).

Summarizing, the correspondance is:

P1.1 , IN1	->	LED LD14
P1.2 , IN2	->	LED LD13
P3.2 , IN3	->	LED LD12
P3.3 , IN4	->	LED LD11
P3.4 , IN5	->	LED LD10
P3.5 , IN6	->	LED LD9
P3.6 , IN7	->	LED LD8
P3.7 , IN8	->	LED LD7

RTC + SRAM

CAN GM Zero & GMB HR84 feature a Real Time Clock + SRAM module already installed.

The SRAM module, is provided with 240 bytes and the Real Time Clock which manages time (hours, minutes, seconds) and date (day, month, year, day of the week).

It is delivered with on board Lithium battery installed.

RTC section can also generate periodic interrupts whose period can be programmed by the user, so it can be used to awaken CPU from low consumption working modes.

For software management of serial SRAM+RTC module, please refer to specific documentation or to demo programs supplied with the card.

The user must realize a serial communication with I²C bus standard protocol, through two ZC1 socket signals.

The only necessary information is the electric connection:

DATA line (SDA)	->	P2.1 (input/output)
CLOCK line (SCL)	->	P2.0 (output)

Please remark that A0 of this component's slave address is bound to logic 0, so its slave address is hexadecimal **A0H**.

Logic state 0 of line corresponds to low level logic state (= 0 V), while logic state 1 corresponds to high level logic state (= 5 V).

We also would want to remark that SDA and SCL lines are connected to a 4.7 KΩ pull-up resistor.

DIGITAL TTL I/O

They are pins 2, 6 and 8 of connector CN4, connected respectively to signals P2.2, P1.3 and P1.0. Pin 8 of CN4 can also be used as digital I/O connected to signal P1.0 (if J6 is connected in position 1-2), but remembering that it is always connected to a 4.7 k Ω pull-down.

In addition, pin 4 is connected to a LED (LD6) that visualizes its status.

This signal is connected to Real Time Clock open collector output /INTRTC and cannot be used as user digital I/O.

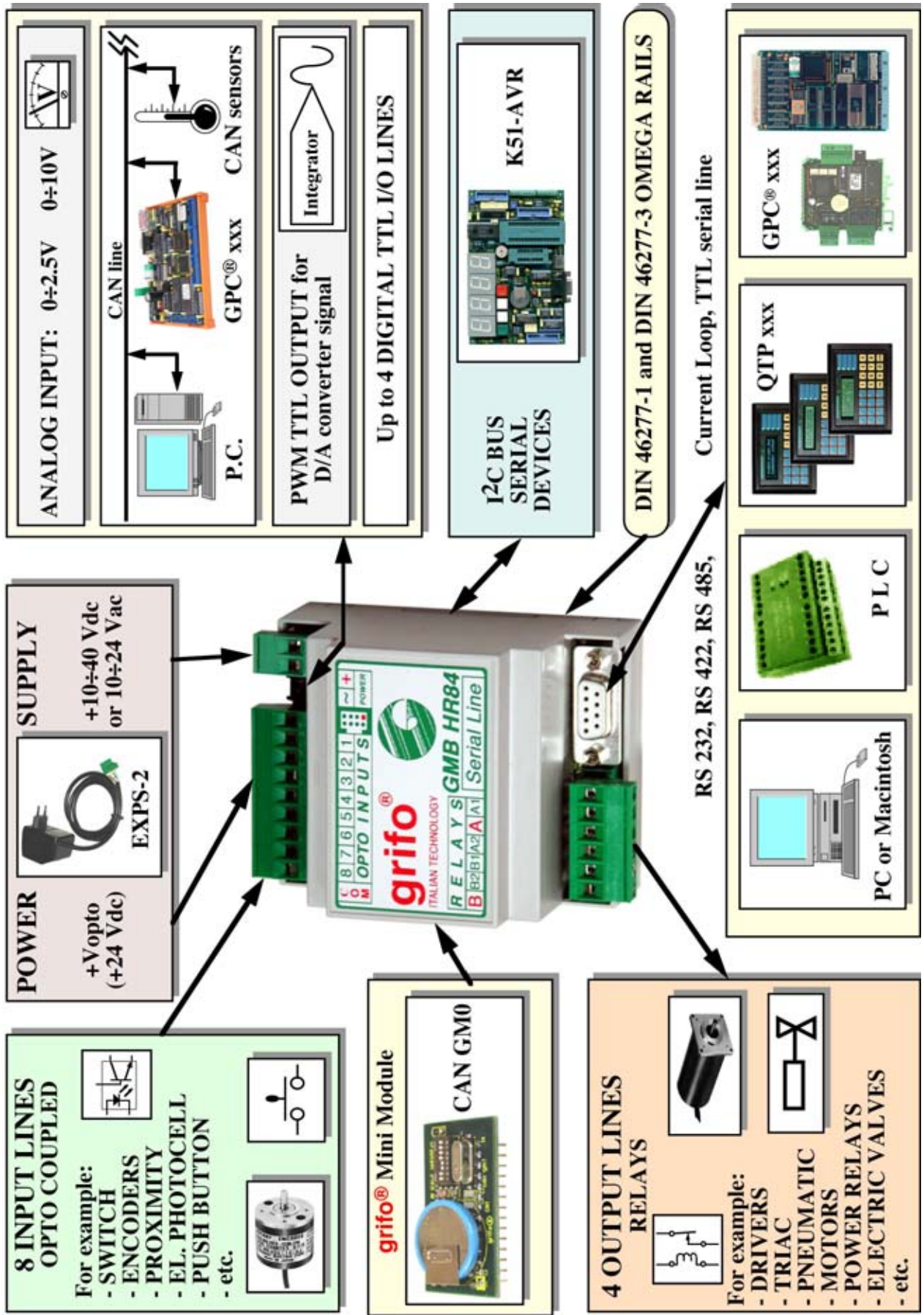

FIGURE 34: CONNECTIONS EXAMPLE



APPENDIX A: ALPHABETICAL INDEX

A

ANALOG INPUT 10, 20, 24
ANALOG INPUT RANGE 11

B

BACK UP 24

C

CAN 8, 10, 20
COM 1 16
CONNECTORS 10
 CN3 18
 CN5 12
 CN6 14
 CN7 20
 CN8 13
CONTAINER 10
CURRENT LOOP 10, 14
CURRENT ON +5 VDC 11
CURRENT REQUIRED 11
CUT-OFF FREQUENCY 10

D

DIGITAL INPUTS 10, 16, 37
DIN 10
DIR 10

E

EXPS-2 22

H

HOW TO START 26

I

I/O TTL 6, 10, 20, 38
I²C BUS 8, 10, 11, 13, 36
IN 16

L

LED 10, 37

N

NPN 6, 10, 16

O

OPTOCOUPLED INPUTS 37

OPTOCOUPLED INPUT VOLTAGE 11

P

PNP 6, 10, 16

POWER REQUIRED FOR OPTOCOUPLEDERS 11

POWER SUPPLY 10, 11, 12, 22

POWER SUPPLY TO OPTOCOUPLEDERS 22

R

REAL TIME CLOCK 24, 37

RELATIVE HUMIDITY 10

RELAY OUTPUTS 6, 10, 18, 36

RELAYS MAX CURRENT 11

RS 232 14

RS 422 10, 14

RS 485 10, 14

S

SCL 13, 36, 37

SDA 13, 36, 37

SIZE 10

SLAVE ADDRESS 36

SRAM 37

SWITCHING 10

T

TEMPERATURE RANGE 10

TERMINATION NETWORK RS 422-485 11

TRANSZORB™ 22

TTL 14

W

WEIGHT 10